

Ses # 02984

INSTRUCTION MANUAL

BK PRECISION 1472C

15 MHz, TRIGGERED SWEEP Dual-Trace Oscilloscope

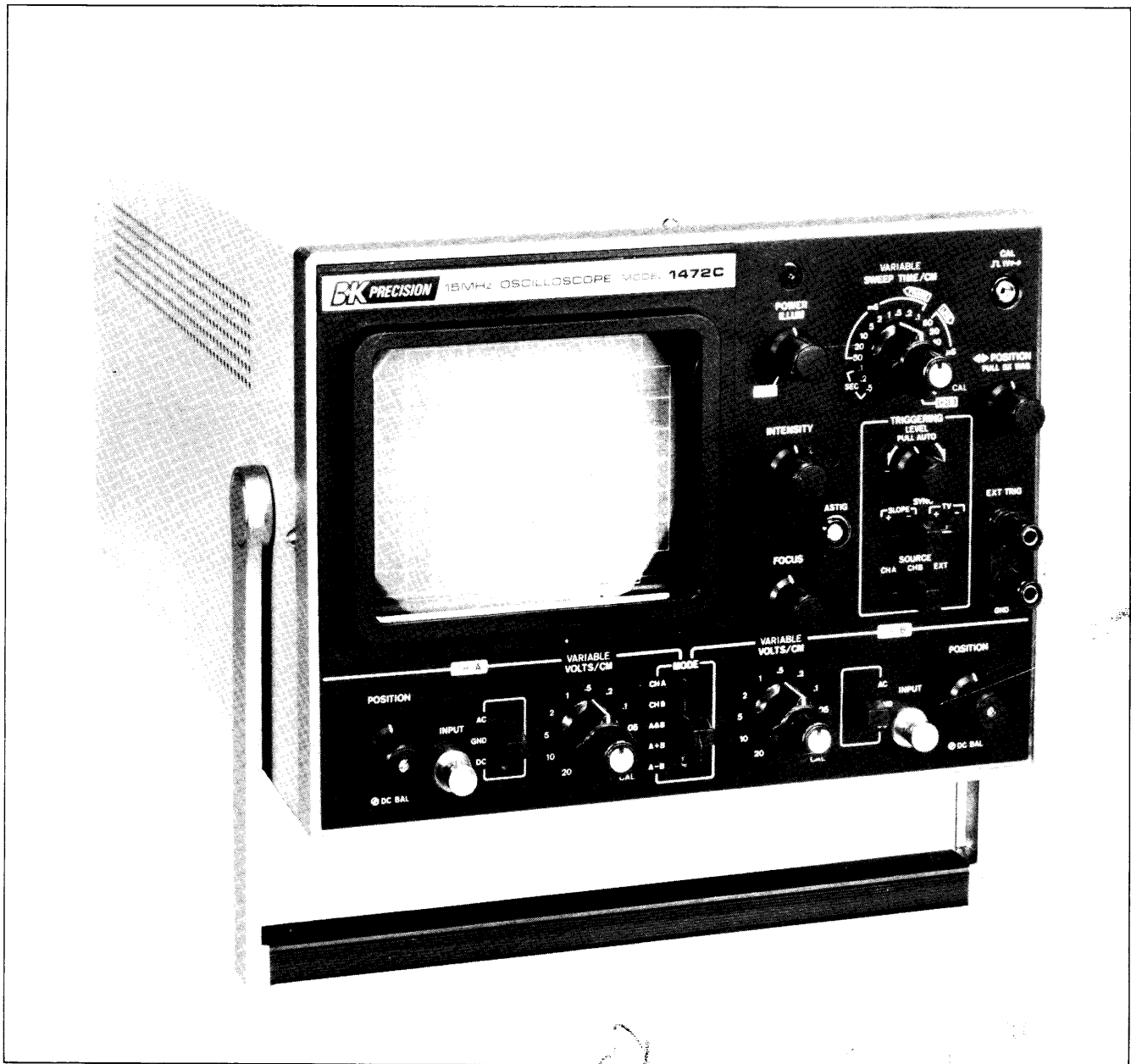

BK PRECISION

A Product of DYNASCAN CORPORATION 1801 West Belle Plaine • Chicago, Illinois 60613

PRICE \$3.00



INSTRUCTION MANUAL
FOR
B & K-PRECISION
MODEL 1472C
15 MHz, TRIGGERED SWEEP
DUAL-TRACE OSCILLOSCOPE



DYNASCAN CORPORATION

6460 West Cortland Street

Chicago, Illinois 60635

TABLE OF CONTENTS

	Page
INTRODUCTION	4
FEATURES	4
SPECIFICATIONS	5
OPERATOR'S CONTROLS, INDICATORS AND FACILITIES	7
OPERATING INSTRUCTIONS	
Initial Starting Procedure	8
Single-Trace Waveform Observation	8
Calibrated Voltage Measurement	10
Differential Voltage Measurement	11
Calibrated Time Measurement	12
External Horizontal Input (X-Y Operation)	13
Z-Axis Input	14
Dual-Trace Waveform Observation	14
DUAL-TRACE APPLICATIONS	
Introduction	15
Frequency Divider Waveforms	15
Divide-by-8 Circuit Waveforms	15
Propagation Time Measurement	16
Digital Circuit Time Relationships	16
Distortion Measurement	18
Gated Ringing Circuit	19
Delay Line Tests	19
Stereo Amplifier Servicing	20
Improving the Ratio of Desired-to-Undesired Signals	20
Amplifier Phase Shift Measurements	20
Television Servicing	21
SINGLE-TRACE APPLICATIONS	
Introduction	23
Television Servicing	23
Signal Tracing and Peak-to-Peak Voltage Readings	23
Composite Video Waveform Analysis	23
Sync Pulse Analysis	25
VITS (Vertical Interval Test Signal)	25
Vectorscope Operation	27
TELEVISION ALIGNMENT	
Introduction	30
Importance of Sweep Alignment	30
Sweep Alignment Methods	31
Tuner Alignment	32
IF Alignment	32
Chroma Alignment	33

TABLE OF CONTENTS

	Page
FM RECEIVER ALIGNMENT	35
PHASE MEASUREMENT	35
FREQUENCY MEASUREMENT	37
SQUARE WAVE TESTING OF AMPLIFIERS	
Introduction	37
Testing Procedure	38
Analyzing the Waveforms	38
CIRCUIT DESCRIPTION	
General	42
Vertical Preamplifiers	42
Mode Logic	42
Vertical Amplifier	42
Trigger Circuit	42
Sync Amplifier and Inverter	42
CALIBRATION ADJUSTMENTS	
Housing Removal	44
230 VAC OPERATION	44
Graticule Removal	44
CH A and CH B DC Balance	44
1/2 and 1/5 Attenuator Balance	44
Vertical Gain Adjustment	44
Horizontal Position Adjustment	44
WARRANTY SERVICE INSTRUCTIONS	47
WARRANTY	48

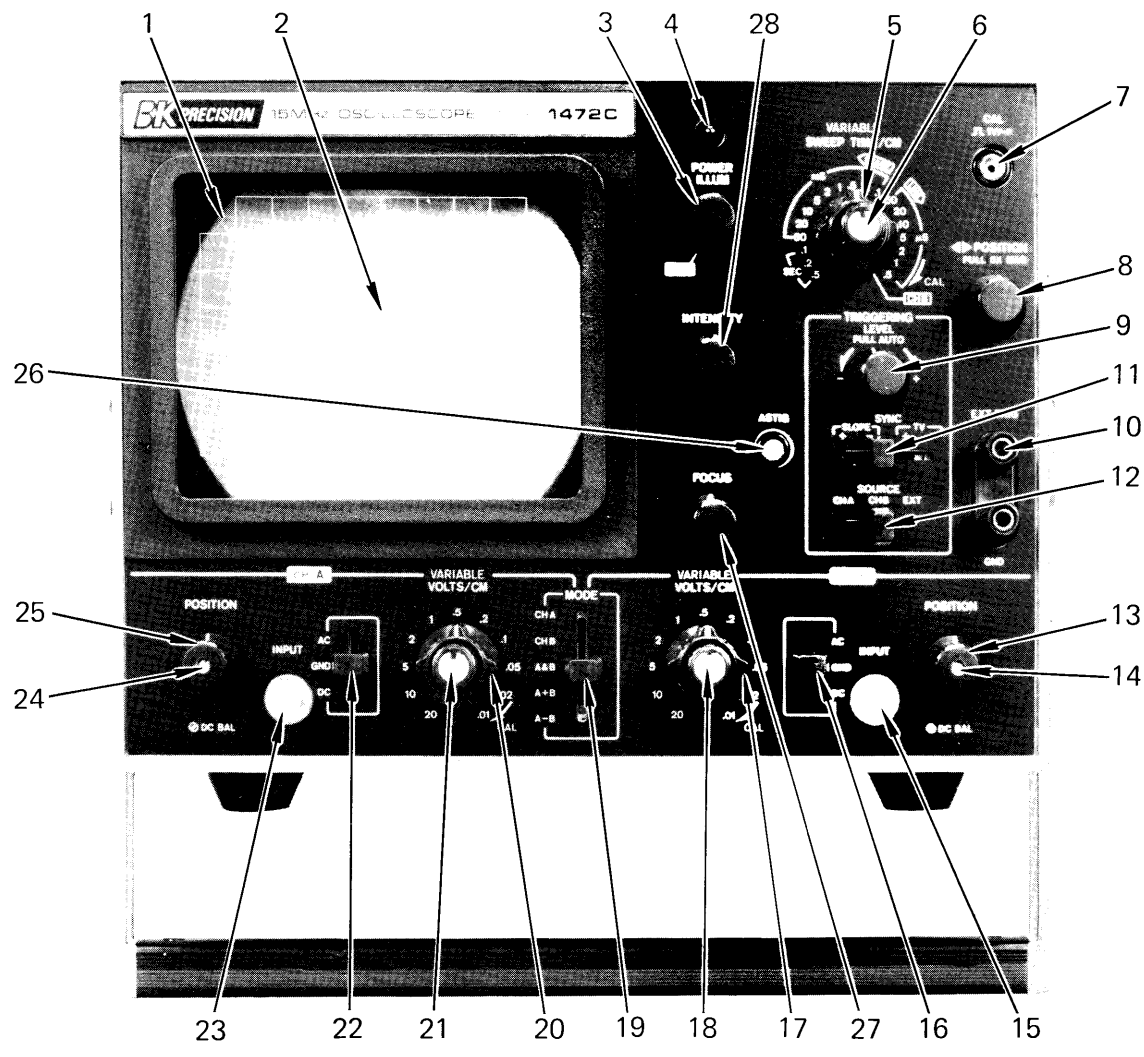

Fig. 1. Front panel controls and indicators.

OPERATOR'S CONTROLS, INDICATORS AND FACILITIES

1. Cathode Ray Tube (CRT). This is the screen on which the waveforms are viewed.
2. Scale. The 8 x 10 cm graticule provides calibration marks for voltage (vertical) and time (horizontal) measurements. Illumination of the scale is fully adjustable.
3. **POWER ILLUM** control. Fully counterclockwise rotation of this control (OFF position) turns off oscilloscope. Clockwise rotation turns on oscilloscope. Further clockwise rotation of the control increases the illumination level of the scale.
4. Pilot lamp. Lights when oscilloscope is turned on.
5. **SWEEP TIME/CM** switch. Horizontal coarse sweep time selector. Selects calibrated sweep times of 0.5 μ SEC/cm (microsecond per centimeter) to 0.5 SEC/cm in 19 steps when **VARIABLE** control 6 is set to the CAL position (fully clockwise). In the CH B position, this switch disables the internal sweep generator and permits the CH B input to provide horizontal sweep.
6. Sweep speed **VARIABLE** control. Fine sweep time adjustment. In the extreme clockwise (CAL) position the sweep time is calibrated.
7. **CAL 1V P-P** jack. Provides calibrated 1 kHz, 1 volt peak-to-peak square wave input signal. This is used for calibration of the vertical amplifier attenuators and to check the frequency compensation adjustment of the probes used with the oscilloscope.
8. **POSITION** control. Rotation adjusts horizontal position of traces (both traces when operated in the dual trace mode). Push-pull switch selects 5X magnification when pulled out (PULL 5X MAG); normal when pushed in.
9. **TRIGGERING LEVEL** control. Sync level adjustment determines points on waveform slope where sweep starts; (–) equals most negative point of triggering and (+) equals most positive point of triggering. Push-pull switch selects automatic triggering when pulled out (PULL AUTO). When automatic triggering, a sweep is generated even without an input signal.
10. **EXT TRIG** jack. Input terminals for external trigger signal.
11. **SYNC** switch. Four-position lever switch with the following positions:
 - SLOPE. The SLOPE positions are used for viewing all waveforms except television composite video signals.
 - (+) Sweep is triggered on positive-going slope of waveform.
 - (–) Sweep is triggered on negative-going slope of waveform.
 - TV. In the TV positions, the sync pulses of a television composite video signal are used to trigger the sweep; the vertical sync pulses (frame) are automatically selected for sweep times of 0.5 SEC/cm to 0.1 mSEC/cm, and horizontal sync pulses (line) are automatically selected for sweep times of 50 μ SEC/cm to .5 μ SEC/cm.
 - (+) Sweep is triggered on positive-going sync pulse.
 - (–) Sweep is triggered on negative-going sync pulse.
12. **SOURCE** switch. Three-position lever switch selects triggering source for the sweep. Both sweeps are triggered by the same source in dual trace operation.
 - CH A Sweep is triggered by Channel A signal.
 - CH B Sweep is triggered by Channel B signal.
 - EXT Sweep is triggered by an external signal applied at the EXT SYNC jack 10.
13. Channel B **POSITION** control. Vertical position adjustment for Channel B trace. Becomes horizontal position adjustment when SWEEP TIME/CM switch 5 is in the CH B position.
14. Channel B **DC BAL** adjustment. Vertical DC balance adjustment for Channel B trace.
15. Channel B **INPUT** Jack. Vertical input jack of Channel B. Jack becomes external horizontal input when SWEEP TIME/CM switch 5 is in the CH B position.
16. Channel B **DC-GND-AC** switch.
 - DC Direct input of AC and DC component of input signal.
 - GND Opens signal path and grounds input to vertical amplifier. This provides a zero-signal base line, the position of which can be used as a reference when performing DC measurements.
 - AC Blocks DC component of input signal.
17. Channel B **VOLTS/CM** switch. Vertical attenuator for Channel B which provides step adjustment of vertical sensitivity. Vertical sensitivity is calibrated in 11 steps from .01 to 20 volts per cm when **VARIABLE** control 18 is set to CAL position. This control adjusts horizontal sensitivity when the SWEEP TIME/CM switch 5 is in the CH B position.
18. Channel B **VARIABLE** control. Vertical attenuator adjustment provides fine control of vertical sensitivity. In the extreme clockwise (CAL) position, the vertical attenuator is calibrated. This control becomes the fine horizontal gain control when the SWEEP TIME/CM switch 5 is in the CH B position.
19. **MODE** switch. Five-position lever switch; selects the basic operating modes of the oscilloscope.
 - CH A Only the input signal to Channel A is displayed as a single trace.
 - CH B Only the input signal to Channel B is displayed as a single trace.
 - A & B Dual trace operation; both the Channel A and Channel B input signals are displayed on two separate traces.
 - A + B The waveforms from Channel A and Channel B inputs are added and the sum is displayed as a single trace.
 - A – B The waveform from Channel B is subtracted from the Channel A waveform and the difference is displayed as a single trace. If only a Channel B input is present, the display is inverted.
20. Channel A **VOLTS/CM** switch. Vertical attenuator for Channel A which provides coarse adjustment of vertical sensitivity. Vertical sensitivity is calibrated in 11 steps

from .01 to 20 volts per cm when VARIABLE control 21 is set to the CAL position.

21. Channel A **VARIABLE** control. Vertical attenuator adjustment provides fine control of vertical sensitivity. In the extreme clockwise (CAL) position, the vertical attenuator is calibrated.
22. Channel A **DC-GND-AC** switch.
 - DC Direct input of AC and DC component of input signal.
 - GND Opens signal path and ground input to vertical amplifier. This provides a zero-signal base line, the position of which can be used as a reference when performing DC measurements.
 - AC Blocks DC component of input signal.
23. Channel A **INPUT** jack. Vertical input jack of Channel A.
24. Channel A **DC BAL** adjustment. Vertical DC balance adjustment for Channel A trace.
25. Channel A **POSITION** control. Vertical position adjustment for Channel A trace.
26. **ASTIG** adjustment. Astigmatism adjustment provides optimum spot roundness when used in conjunction with the **FOCUS** control 27 and **INTENSITY** control 28. Very little readjustment of this control is required after initial adjustment.
27. **FOCUS** control.
28. **INTENSITY** control. Adjusts brightness of trace.
29. Fuse holder.
30. AC line cord. CSA-approved for oscilloscopes.
31. **INT MOD** jack. Intensity modulation (Z-axis) input.
32. Combination carrying handle and tilt stand.
33. Probe (see Fig. 3). The B & K-Precision Model PR-35 combination 10:1/Direct probe has been designed for use with this oscilloscope. However, any probe designed for use with an oscilloscope having a nominal input impedance of 1 megohm shunted by 27 pF and capable of operation up to 15 MHz, can be used.
34. Vector Overlay (not shown). Interchanges with scale for vectorscope operation.

OPERATING INSTRUCTIONS

INITIAL STARTING PROCEDURE

1. Set **POWER ILLUM** control 3 to OFF position (fully counterclockwise).
2. Connect power cord 30 to a 120-volt, 50/60 Hz outlet.
3. Set **CH A POSITION** control 25, **CH B POSITION** control 13 and **POSITION 8** to the centers of their ranges.
4. Pull **TRIGGERING LEVEL** control 9 to the AUTO position.
5. Set **CH A DC-GND-AC** switch 22 and **CH B DC-GND-AC** switch 16 to the GND positions.
6. Set the **MODE** switch 19 to the CH B position for single-trace operation or the A & B position for dual-trace operation.
7. Turn on oscilloscope by rotating the **POWER ILLUM** control 3 clockwise. It will "click" on and pilot lamp 4 will light. Turn control clockwise to the desired scale 2 illumination.
8. Wait a few seconds for the cathode ray tube (CRT) to warm up. A trace (two traces if operating in the A & B mode) should appear on the face of the CRT.
9. If no trace appears, increase (clockwise) the **INTENSITY** control 28 setting until the trace is easily observed.
10. Adjust **FOCUS** control 27 and **INTENSITY** control 28 for the thinnest, sharpest trace.
11. Readjust position controls 8, 25 and 13 if necessary, to center the traces.
12. Check for proper adjustment of **ASTIG** control 26, and **DC BAL** controls 14 and 24 as described in the **MAINTENANCE AND CALIBRATION** portion of this manual. These adjustments require checking only periodically.

The oscilloscope is now ready for making waveform measurements.

CAUTION

Never allow a small spot of high brilliance to remain stationary on the screen for more than a few seconds. The screen may become permanently burned. Reduce intensity or keep the spot in motion by causing it to sweep.

SINGLE-TRACE WAVEFORM OBSERVATION

Either Channel A or Channel B can be used for single-trace operation. The advantage of using Channel B is that the polarity of the observed waveform can be reversed by placing the **MODE** switch 19 in the A-B position if there is no input to Channel A. For convenience, Channel B is used in the following instructions.

1. Perform the steps of the "Initial Starting Procedure" with the **MODE** switch 19 in the CH B position. Then connect the probe cable to the CH B **INPUT** jack 15. The following instructions assume the use of the **B & K-Precision Model PR-35** combination probes.
2. For all except low-amplitude waveforms, the probes are set for 10:1 attenuation. For low-amplitude waveforms (below 0.5 volt peak-to-peak), set the probe for **DIRECT**. See Fig. 3 for changing the probes from 10:1 to **DIRECT**, or vice versa. The probe has a 10 megohm input impedance with only 18pF shunt capacitance in the 10:1 position and 1 megohm with 120 pF shunt capacitance in the **DIRECT** position. The higher input impedance (low-capacity position) should be used when possible, to decrease circuit loading.
3. Set **CH B DC-GND-AC** switch 16 to **AC** for measuring only the AC component (this is the normal position for

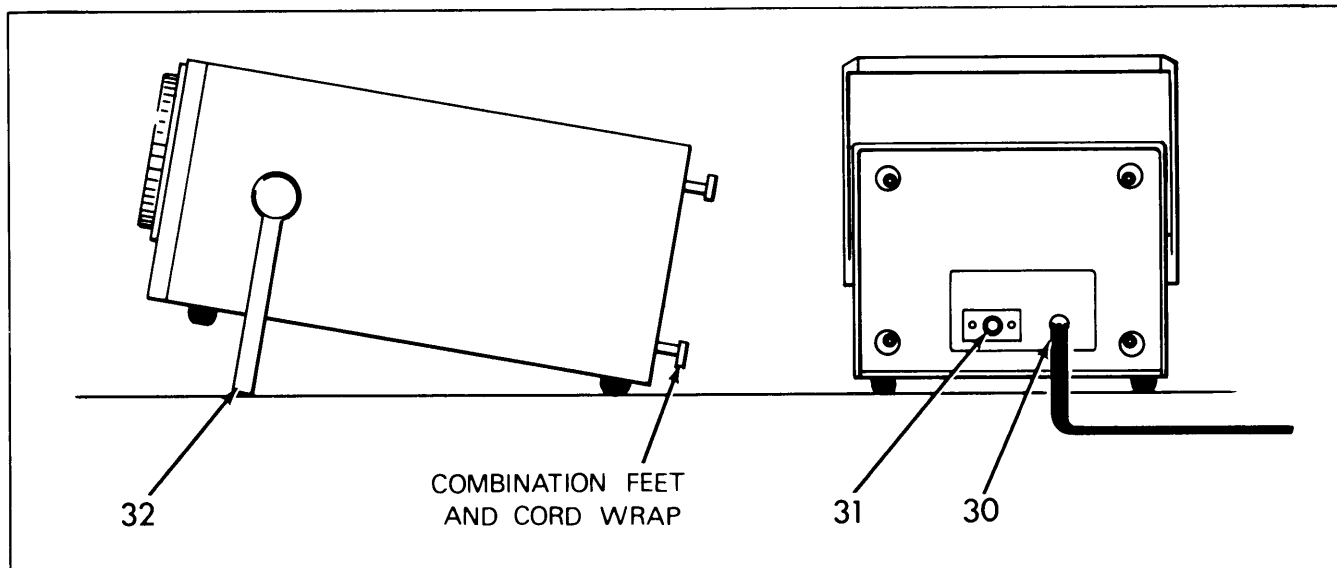

Fig. 2. Rear and side panel facilities.

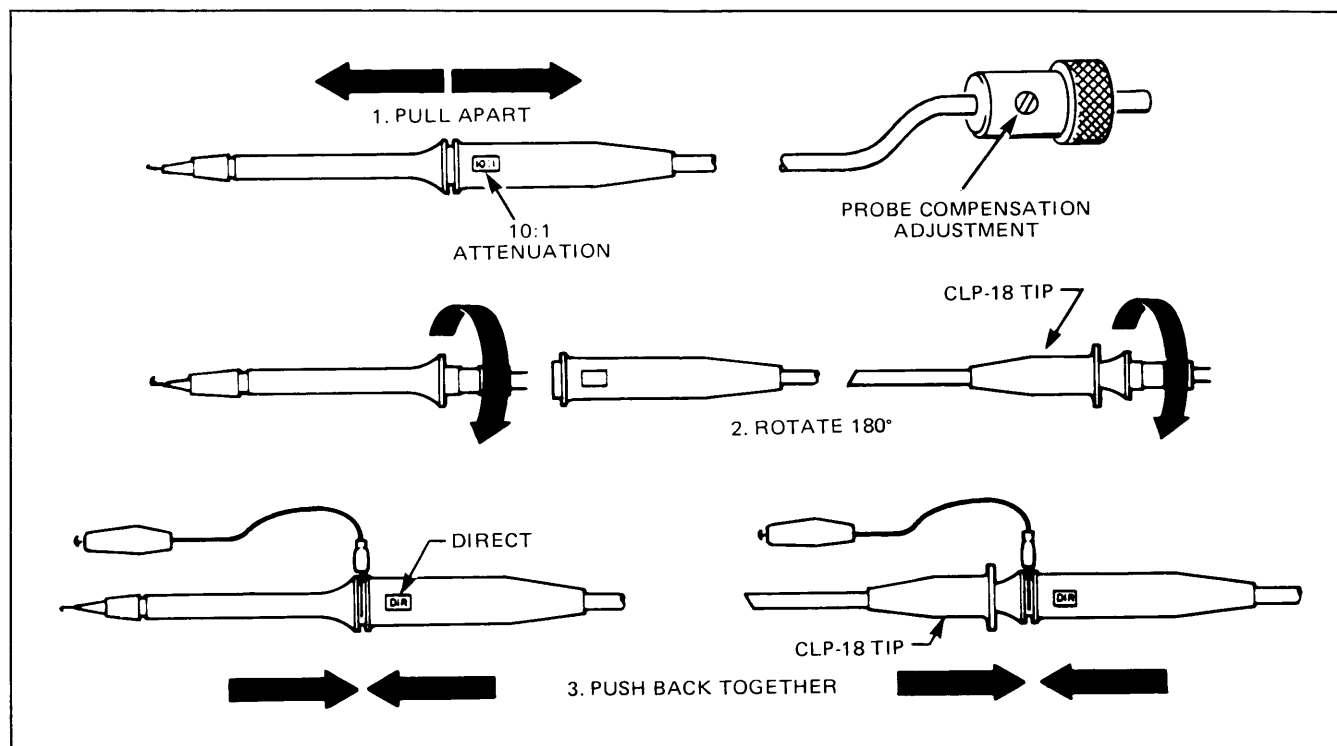

Fig. 3. Probe details.

most measurements and must be used if the point being measured includes a large DC component). Use the DC position for measuring both the AC component and the DC reference, and any time a very low frequency waveform (below 5 Hz) is to be observed. The GND position is required only when a zero-signal ground reference is required, such as for DC voltage readings.

4. Connect ground clip of probe to chassis ground of the equipment under test. Connect the tip of the probe to the point in the circuit where the waveform is to be measured.

WARNING

- a. If the equipment under test is a transformerless AC powered item, use an isolation transformer to prevent dangerous electrical shock.
 - b. The peak-to-peak voltage at the point of measurement should not exceed 600 volts when using the DIRECT position of the probe.
5. Set CH B VOLTS/CM switch 17 and the VARIABLE control 18 to a position that gives 2 to 6 cm (two to six large squares on the scale) vertical deflection. The display on the screen will probably be unsynchronized. The remaining steps are concerned with adjusting synchronization and sweep speed, which presents a stable display showing the desired number of waveforms. *Any signal that produces at least 1 cm vertical deflection develops sufficient trigger signal to synchronize the sweep.*
 6. Set SOURCE switch 12 to the CH B position. This provides internal sync so that the Channel B waveform being observed is also used to trigger the sweep. During single trace operation on Channel A, the SOURCE switch should be placed in the CH A position for internal sync. Most waveforms should be viewed using internal sync. When an external sync source is required, the SOURCE switch should be placed in the EXT position and a cable should be connected from the EXT TRIG jack 10 to the external sync source.
 7. Set SYNC switch 11 to the TV(+) or TV(-) positions for observing television composite video waveforms or to the SLOPE(+) or SLOPE(-) positions for observing all other types of waveforms. Use the (+) position if the sweep is to be triggered by a positive-going wave, or the (-) position if the sweep is to be triggered by a negative-going wave. If the type of waveform is unknown, the SLOPE(+) position may be used.
 8. Readjust TRIGGERING LEVEL control 9 to obtain a synchronized display without jitter. As a starting point, the control may be pushed in and rotated to any point that will produce a sweep, which is usually somewhere in the center portion of its range. The trace will disappear if there is inadequate signal to trigger the sweep, such as when measuring DC or extremely low amplitude waveforms. If no sweep can be obtained, pull the control out (PULL AUTO) for automatic triggering.
 9. Set SWEEP TIME/CM switch 5 and VARIABLE control 6 for the desired number of waveforms. These controls may be set for viewing only a portion of a waveform, but the trace becomes progressively *dimmer*

as a smaller portion is displayed. This is because the sweep speed increases but the sweep repetition rate does not change.

NOTE

When using very fast sweep speed at low repetition rates, the operator may wish to operate with the intensity control toward maximum. Under these conditions, a retrace "pip" may appear at the extreme left of the trace. This does not in any way affect the oscilloscope operation and may be disregarded.

10. After obtaining the desired number of waveforms, as in step 9, it is sometimes desirable to make a final adjustment of the TRIGGERING LEVEL control 9. The (-) direction selects the most negative point on the waveform at which sweep triggering will occur and the (+) direction selects the most positive point on the waveform at which sweep triggering will occur. The control may be adjusted to start the sweep on any desired portion of the waveform.
11. For a close-up view of a portion of the waveform, pull outward on the ◀▶ POSITION control 8. This expands the sweep by a factor of five (5X magnification) and displays only the *center* portion of the sweep. To view a portion to the left of center, turn the ◀▶ POSITION control clockwise, and to view portions to the right of center, turn the control counterclockwise. Push inward on the control to return the sweep to the normal, non-magnified condition.

CALIBRATED VOLTAGE MEASUREMENT (See Fig. 4)

Peak voltages, peak-to-peak voltages, DC voltages and voltages of a specific portion of a complex waveform are easily and accurately measured on the Model 1472C oscilloscope.

1. Adjust controls as previously instructed to display the waveform to be measured.
2. Be sure the CH B vertical VARIABLE control 18 is set fully clockwise to the CAL position.
3. Set CH B VOLTS/CM switch 17 for the maximum vertical deflection possible without exceeding the limits of the vertical scale.
4. Read the amount of vertical deflection (in cm) from the scale. The CH B POSITION control 13 may be readjusted to shift the reference point for easier scale reading if desired. When measuring a DC voltage, adjust the CH B POSITION control 13 to a convenient reference with the CH B DC-GND-AC switch 16 in the GND position, then note the amount the trace is deflected when the switch is placed in the DC position. The trace deflects upward for a positive voltage input and downward for a negative voltage input.

NOTE

For an accurate display of high-frequency waveforms above 10 MHz, it is important that (1) the probe be used in the 10:1 position to reduce circuit loading; (2) the oscilloscope controls be set so that the height of the pattern does not exceed 4 cm; and (3) the trace be centered vertically.

5. Calculate the voltage reading as follows: Multiply the vertical deflection (in cm) by the VOLTS/CM control 17 setting (see example in Fig. 4). Don't forget that the voltage reading displayed on the oscilloscope is only 1/10th the actual voltage being measured when the

probe is set for 10:1 attenuation. The actual voltage is displayed when the probe is set for DIRECT measurement.

6. Calibration accuracy of this oscilloscope may be occasionally checked by observing the 1 volt peak-to-peak square wave signal available at the CAL 1V P-P jack 7. This calibrated source should read exactly 1 volt peak-to-peak. If a need for recalibration is indicated, see the "MAINTENANCE AND CALIBRATION" section of the manual for complete procedures.

DIFFERENTIAL VOLTAGE MEASUREMENT (See Fig. 5)

This oscilloscope may be used to observe waveforms and measure voltages between two points in a circuit, neither of which is circuit ground. Such measurements as the inputs to a differential amplifier, the output of a phase splitter or push-pull amplifier, the amount of signal developed across a single section of voltage divider or attenuator, and many others, require this technique.

1. Adjust controls as previously described under "Initial Starting Procedure."
2. Connect a probe cable to both the CH A and CH B INPUT jacks 23 and 15.

3. Connect ground clips of the two probes to the chassis of equipment under test, and connect tips of the probes to the points in the circuit where measurements are to be made. It is usually desirable to connect the CH A probe to the higher potential or higher amplitude point in the circuit and the CH B probe to the lower potential or lower amplitude point in the circuit.
4. Set the MODE switch 19 to the CH A position and the SOURCE switch 12 to the CH A position and adjust the controls as previously instructed in the "Single-Trace Waveform Observation" procedure to obtain a synchronized single waveform of 2 to 6 cm vertical height with the CH A VARIABLE control 21 set to CAL.
5. If only the AC component of the waveform is of interest, use the following procedure:
 - a. Set CH A and CH B DC-GND-AC switches 22 and 16 both to the AC position.
 - b. Set CH B VARIABLE control 18 to CAL and the CH B VOLTS/CM switch 17 to the same position as the CH A VOLTS/CM switch 20.
 - c. If the Channel A and Channel B inputs are in phase, set the MODE switch 19 to the A-B position. The displayed waveform is the peak-to-peak difference between the two points of meas-

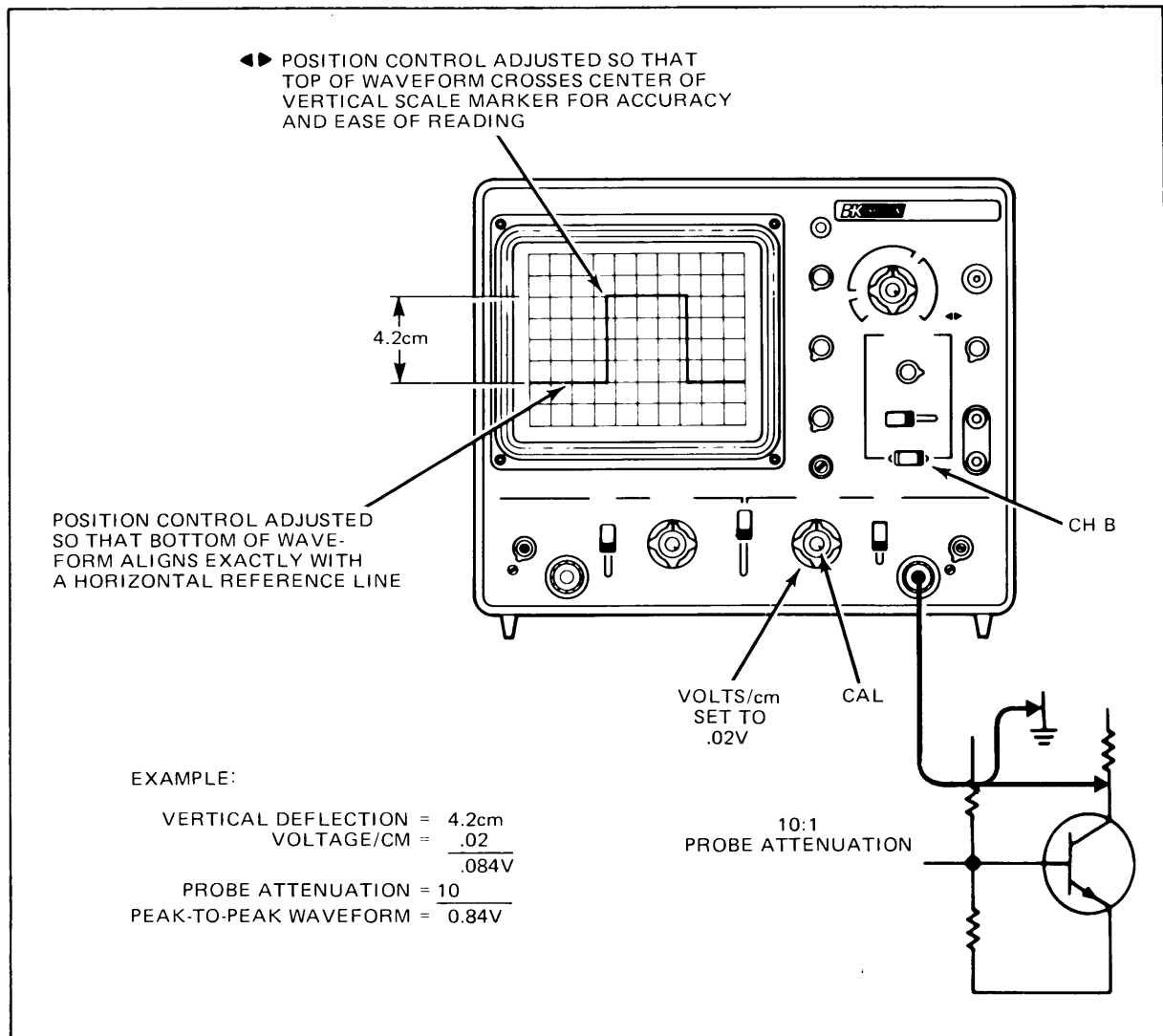

Fig. 4. Typical voltage measurement.

urement. If the waveform is small, the vertical sensitivity may be increased but the CH A and CH B VOLTS/CM switches must both be in the same position.

- d. If the Channel A and Channel B inputs are 180° out of phase, such as the output of a push-pull amplifier, set the MODE switch 19 to the A-B position to measure the full peak-to-peak waveform. Set the MODE switch to the A+B position to measure any imbalance between the two points of measurement. Readjust the VOLTS/CM switches 17 and 20 as required to obtain as large a waveform as possible without exceeding the limits of the vertical scale, but always keep the CH A and CH B switches set to the same sensitivity.
- e. Position the waveform as desired with the positioning controls and calculate the peak-to-peak voltage as described in the "Calibrated Voltage Measurement" procedure.

6. If a DC voltage, or the DC component of the waveform is of interest, use the following procedure:
 - a. Set CH A DC-GND-AC switch 22 to the DC position.
 - b. Position the CH A VOLTS/CM switch 20 to keep the trace within the limits of the vertical scale. Use the CH A POSITION control 25 to align the trace with one of the lines on the scale for reference.
 - c. Position CH B VOLTS/CM switch 17 to the same position as the CH A VOLTS/CM switch.
 - d. Set CH B DC-GND-AC switch 16 to the GND position and adjust out any error that may be introduced by the Channel B positioning control as follows: Alternately set the MODE switch 19 to the A+B and A-B positions, adjusting the CH B POSITION control 13 until the trace position does not shift as the MODE switch position changes.
 - e. Return CH B DC-GND-AC switch 16 to the DC position.
 - f. Momentarily return the MODE switch 19 to the CH A position and note the trace position for reference. You may readjust it with the Channel A vertical positioning control, but not the Channel B control. Place the MODE switch in the A-B position. The amount of displacement of the trace from the Channel A reference represents the voltage differential between the two points of measurement.

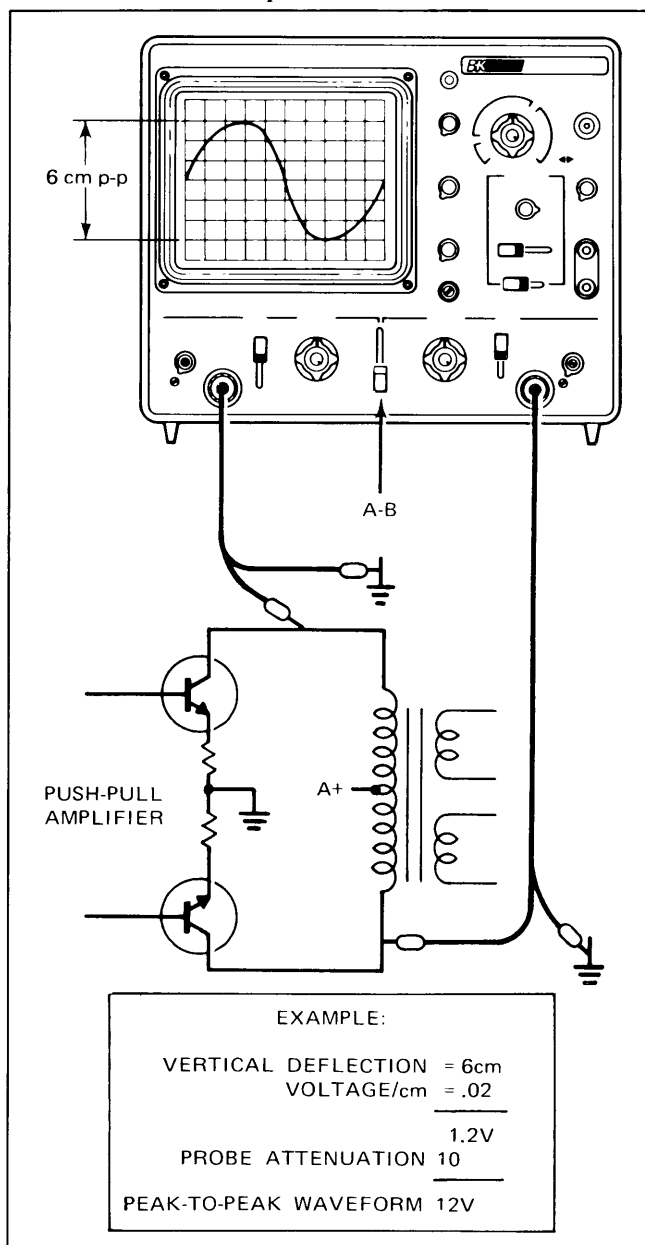

Fig. 5. Typical differential measurement.

CALIBRATED TIME MEASUREMENT (See Fig. 6)

Pulse width, waveform periods, circuit delays and all other waveform time durations are easily and accurately measured on this oscilloscope. Calibrated time measurements from .5 second down to 0.1 microsecond are possible. At low sweep speeds, the entire waveform is not visible at one time. However, the bright spot can be seen moving from left to right across the screen, which makes the beginning and ending points of the measurement easy to spot.

1. Adjust controls as previously described for a stable display of the desired waveform.
2. Be sure the sweep time VARIABLE control 6 is fully clockwise to the CAL position.
3. Set the SWEEP TIME/CM control 5 for the largest possible display of the waveform segment to be measured, usually one cycle.
4. If necessary, readjust the TRIGGERING LEVEL control 9 for the most stable display.
5. Read the amount of horizontal deflection (in cm) between the points of measurement. The ◀▶ POSITION control 8 may be readjusted to align one of the measurement points with a vertical scale marker for easier reading.
6. Calculate the time duration as follows: Multiply the horizontal deflection (in cm) by the SWEEP TIME/CM switch 5 setting (see example in Fig. 5). Remember, when the 5X magnification is used, the result must be divided by 5 to obtain the actual time duration.
7. Time measurements often require external sync. This is especially true when measuring delays. The sweep is started by a sync signal from one circuit and the

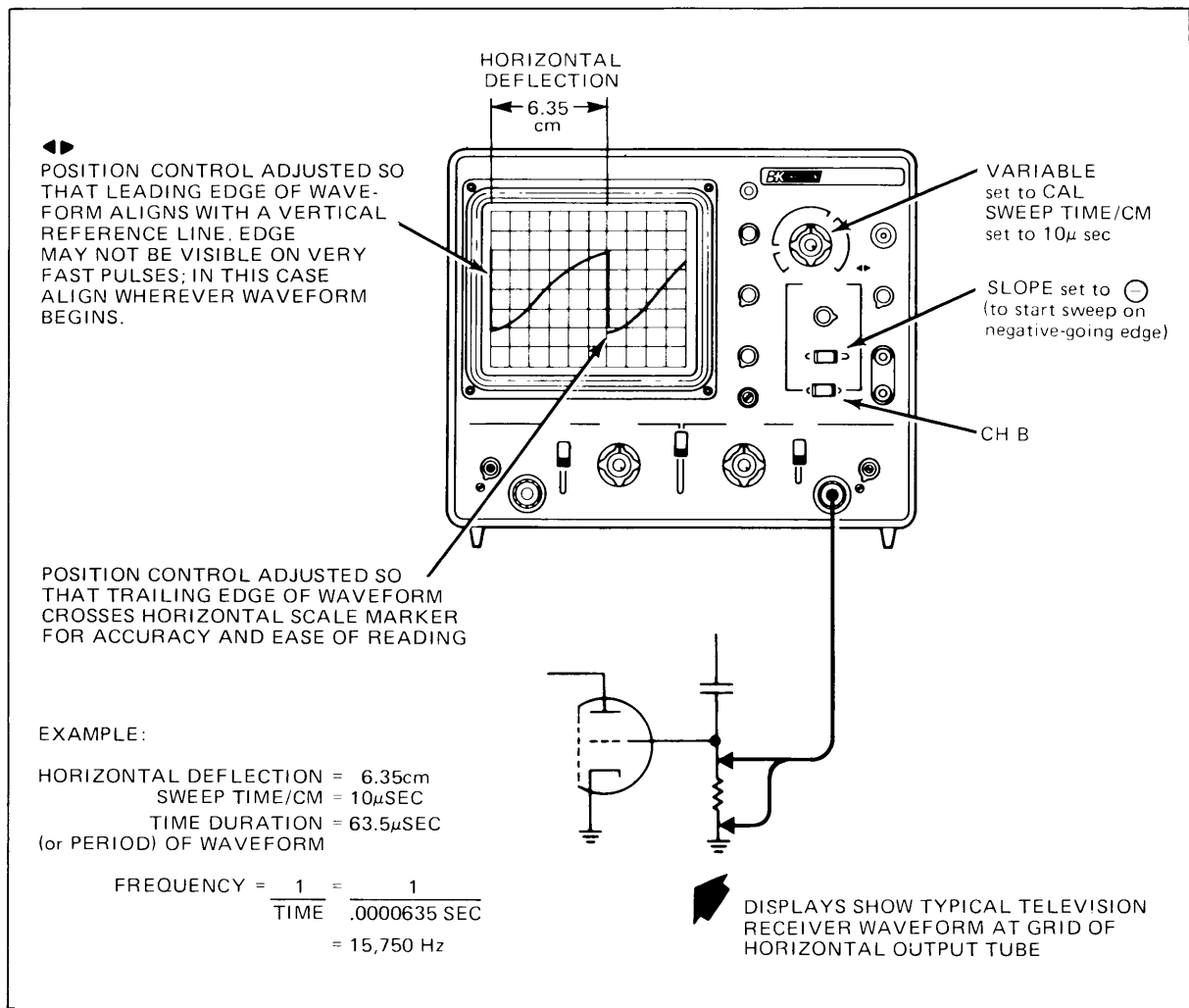

Fig. 6. Typical time measurement.

waveform measured in a subsequent circuit. This allows measurement of the display between the sync pulse and the subsequent waveform. To perform such measurements using external sync, use the following steps:

- a. Set the SOURCE switch 12 to the EXT position.
 - b. Connect a cable from the EXT TRIG jack 10 to the source of sync signal. Use a short shielded cable.
 - c. Set the SYNC switch 11 to the SLOPE (+) or (−) position for the proper polarity for the sync signal.
 - d. Readjust the TRIGGERING LEVEL control 9 if necessary for a stable waveform.
 - e. If measuring a delay, measure the time from the start of the sweep to the start of the waveform.
8. Another excellent method for measuring time delays is with dual-trace operation. The procedures are given in the "DUAL-TRACE APPLICATIONS" section of the manual.

EXTERNAL HORIZONTAL INPUT (X-Y OPERATION)

For some measurements, an *external* horizontal deflection signal is required. This is also referred to as an X-Y measurement, where the Y input provides vertical deflection and the X input provides horizontal deflection. The horizontal input may be a sinusoidal wave, such as for

phase measurement, or an external sweep voltage. This input must be 10 mV per cm of deflection or greater; thus any voltage of 100 mV or greater is sufficient for satisfactory operation. To use an external horizontal input, use the following procedure:

1. Set the SWEEP TIME/CM switch 5 fully clockwise to the CH B position.
2. Use the Channel A probe for the vertical input and the Channel B probe for the horizontal input.
3. Adjust the amount of horizontal deflection with the CH B VOLTS/CM and VARIABLE controls 17 and 18.
4. The CH B (vertical) POSITION control now serves as the horizontal position control, and the ◀ POSITION control is disabled.

NOTE

Do NOT use the PULL 5X MAG control during X-Y operation. Use the CH B VARIABLE and VOLTS/CM controls to adjust horizontal gain.

5. All sync controls are disconnected and have no effect.

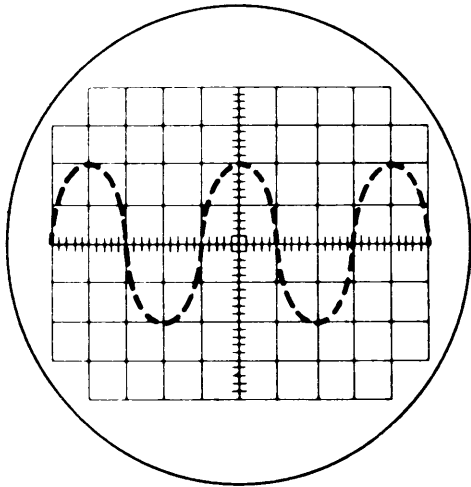

Fig. 7. Oscilloscope trace with Z-axis input.

Z-AXIS INPUT

The trace displayed on the screen may be intensity modulated (Z-axis input) where frequency or time-scale marks are required. A 20-volt peak-to-peak or greater signal applied at the INT MOD (intensity modulation) jack 31 on the rear of the oscilloscope will provide alternate brightness and blanking of the trace. See Fig. 7.

DUAL-TRACE WAVEFORM OBSERVATION (Refer to Fig. 8)

In observing simultaneous waveforms on channels A and B, it is necessary that the waveforms be related in frequency or that one of the waveforms be synchronized to the other although the basic frequencies may be different. An example of this is in checking a frequency divider or multiplier. The reference, or "clock" frequency can be used on Channel A, for example, and the multiple or sub-multiple of this reference frequency will be displayed on Channel B. In this way, when the waveform display of Channel A is synchronized, the display on Channel B will also be in sync with the Channel A display. If two waveforms having no phase or frequency relationship to each other are displayed simultaneously, it will be difficult if not impossible to lock both waveforms in sync for any useful observation.

To display two waveforms simultaneously for observation, use the following procedure:

1. Perform the steps of the "Initial Starting Procedure."
2. Connect oscilloscope probe cables to both the CH A and CH B INPUT jacks 23 and 15.
3. If the recommended **B & K-Precision Model PR-35** oscilloscope probes are used, 10:1 attenuation should be used except for waveforms of 0.5 volt peak-to-peak or less. For the lower amplitude waveforms the DIRect position should be used. See Fig. 3 for changing the probe from 10:1 to DIR or vice versa. Whenever possible, use the high impedance, low capacity 10:1 position to minimize circuit loading.
4. Set MODE switch 19 to the A & B position. Two traces should appear on the screen.
5. Adjust CH A and CH B POSITION controls 25 and 13 to place the Channel A trace above the Channel B trace, and adjust both traces to a convenient reference mark on the scale.

6. Set both the CH A and CH B DC-GND-AC switches 22 and 16 to the AC position. This is the position used for most measurements and must be used if the points being measured include a large DC component.
7. Connect the ground clips of the probes to the chassis ground of the equipment under test. Connect the tips of the probes to points in the circuit where the waveforms are to be measured. It is preferred that the signal to which the waveform will be synchronized be applied to the Channel A input.

WARNING

- a. If the equipment under test is a transformerless AC unit, use an isolation transformer to prevent dangerous electrical shock.
 - b. The peak-to-peak voltage at the point of measurement should not exceed 600 volts, if the probe is used in the DIR position.
8. Set the VOLTS/CM controls 17 and 20 for Channels A and B to a position that gives 2 to 3 cm vertical deflection. The displays on the screen will probably be unsynchronized. The remaining steps, although similar to those outlined for single-trace operation, describe the procedure for obtaining stable, synchronized displays.
 9. Set the SOURCE switch 12 to the CH A position. This provides internal sync so that the Channel A waveform being observed is also used to trigger the sweep. If desired, the Channel B waveform may be used to trigger the sweep by setting the SOURCE switch to the CH B position. Often in dual-trace operation, a sync source other than the measurement point for Channel A or B is required. In this case set the SOURCE switch to the EXT (external) position and connect a cable from the EXT TRIG jack 10 to the sync source.
 10. Set the SYNC switch 11 to the TV(+) or TV(-) positions for observing television composite video waveforms, or to the SLOPE (+) or SLOPE (-) positions for observing all other types of waveforms. Use the (+) positions if the sweep is to be triggered by a positive-going wave, or to the (-) position if the sweep is to be triggered by a negative-going wave.
 11. Adjust TRIGGERING LEVEL control 9 to obtain a stable, synchronized sweep. As a starting point, the control may be pushed in and rotated to any point that will produce a sweep, which is usually somewhere in the center portion of its range. The trace will disappear if there is inadequate signal to trigger the sweep, such as when measuring extremely low amplitude signals. If no sweep can be obtained, pull out the control (PULL AUTO) for automatic triggering.
 12. Set SWEEP TIME/CM switch 5 and VARIABLE control 6 for the desired number of waveforms. These controls may be set for viewing only a portion of a waveform, but the trace becomes progressively dimmer as a smaller portion is displayed.
 13. After obtaining the desired number of waveforms as in step 12, it is sometimes desirable to make a final adjustment of the TRIGGERING LEVEL control 9. The (-) direction of rotation selects the most negative point on the sync waveform at which sweep triggering will occur and the (+) direction selects the most positive point on the sync waveform at which sweep triggering will occur. The control may be adjusted to start the sweep on any desired portion of the sync waveform.

14. The observed waveforms of Channels A and B can be expanded by a factor of 5 by pulling outward on the ◀ POSITION control 8. This control can then be rotated clockwise or counterclockwise to view the left and right extremes of the waveform displays as desired. Push inward on the control to return the sweep to the normal, non-magnified condition.
15. Calibrated voltage measurements, calibrated time measurements and operation with Z-axis input are identical to those previously described for single-trace operation. Either the Channel A or Channel B vertical adjustment controls can be used as required in conjunction with the horizontal sweep controls to obtain the required amplitude or time interval measurements. This can be done either by using the dual display facilities such as the A & B position of the MODE switch or by reverting to single-trace operation, using the CH A or CH B positions of the MODE switch.
16. The Channel A and Channel B waveform displays can be added algebraically by placing the MODE switch in the A+B position, or subtracted algebraically in the A-B position.

DUAL-TRACE APPLICATIONS

INTRODUCTION

The most obvious and yet the most useful feature of the dual-trace oscilloscope is that it has the capability for viewing simultaneously two waveforms that are frequency- or phase-related, or that have a common synchronizing voltage, such as in digital circuitry. Simultaneous viewing of "Cause and Effect" waveforms is an invaluable aid to the circuit designer or the repairman. Several possible applications of the dual-trace oscilloscope will be reviewed in detail to familiarize the user further in the basic operation of this oscilloscope.

FREQUENCY DIVIDER WAVEFORMS

Fig. 8 illustrates the waveforms involved in a basic divide-by-two circuit. Fig. A indicates the reference or "clock" pulse train. Fig. B and Fig. C indicate the possible outputs of the divide-by-two circuitry. Fig. 8 also indicates the settings of specific oscilloscope controls for viewing these waveforms. In addition to these basic control settings, the TRIGGERING LEVEL control, as well as the Channel A and Channel B vertical position controls should be set as required to produce suitable displays. In the drawing of Fig. 8, the waveform levels of 2 cm are indicated. If the exact voltage amplitudes of the Channel A and Channel B waveforms are desired, the Channel A and Channel B VARIABLE controls must be placed in the CAL position. The Channel B waveform may be either that indicated in Fig. 8B or 8C. In Fig. 8C the divide-by-two output waveform is shown for the case where the output circuitry responds to a negative-going waveform. In this case, the output waveform is shifted with respect to the leading edge of the reference frequency pulse by a time interval corresponding to the pulse width.

DIVIDE-BY-8 CIRCUIT WAVEFORMS

Fig. 9 indicates waveform relationships for a basic divide-by-eight circuit. The basic oscilloscope settings are identical to those used in Fig. 8. The reference frequency of Fig. 9A is supplied to the Channel A input, and the divide-by-eight output is applied to the Channel B input. Fig. B indicates the ideal time relationship between the input pulses and the output pulse.

In an application where the logic circuitry is operating at or near its maximum design frequency, the accumulated rise time effects of the consecutive stages produce a built-in time propagation delay which can be significant in a critical circuit and must be compensated for. Fig. 9C indicates the possible time delay which may be introduced into a frequency divider circuit. By use of the dual trace oscilloscope the input and output waveforms can be superimposed

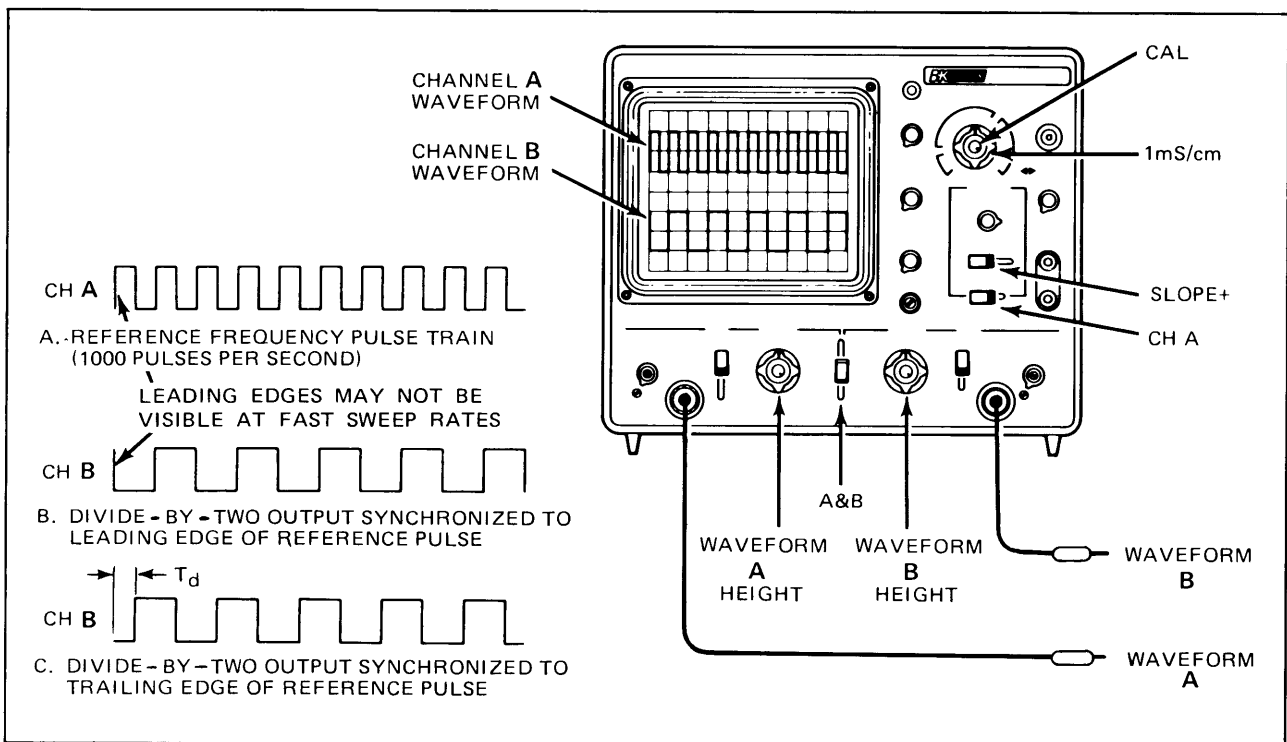

Fig. 8. Waveforms in divide-by-two circuit.

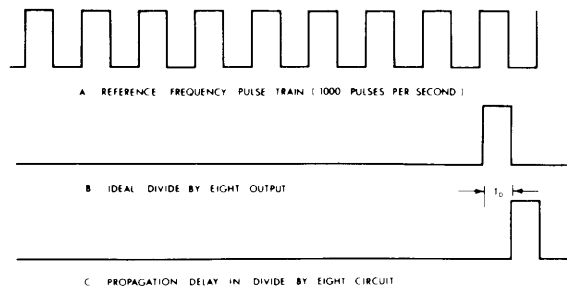

Fig. 9. Waveforms in divide-by-eight circuit.

to determine the exact amount of propagation delay that occurs.

PROPAGATION TIME MEASUREMENT

An example of propagation delay in a divide-by-eight circuit was given in the previous paragraph. Significant propagation delay may occur in any circuit with several consecutive stages. This oscilloscope has features which simplify measurement of propagation delay. Fig. 10 shows the resultant waveforms when the dual-trace presentation is combined into a single-trace presentation by selecting the A+B or A-B position of the MODE switch. In the A+B position the two inputs are algebraically added in a single trace display. Similarly, in the A-B position the two inputs are algebraically subtracted. Either position provides a precise display of the propagation time (T_p). Using the procedures given for calibrated time measurement, T_p can be calculated. A more precise measurement can be obtained if the T_p portion of the waveform is expanded hori-

zontally. This may be done by pulling the PULL 5X MAG control. It also may be possible to view the desired portion of the waveform at a faster sweep speed.

DIGITAL CIRCUIT TIME RELATIONSHIPS

A dual-trace oscilloscope is a necessity in designing, manufacturing and servicing digital equipment. A dual-trace oscilloscope permits easy comparison of time relationships between two waveforms.

In digital equipment it is common for a large number of circuits to be synchronized, or to have a specific time relationship to each other. Many of the circuits are frequency dividers as previously described, but waveforms are often time-related in many other combinations. In the dynamic state, some of the waveforms change, depending upon the input or mode of operation. Fig. 11 shows a typical digital circuit and identifies several of the points at which waveform measurements are appropriate. The accompanying Fig. 12 shows the normal waveforms to be expected at each of these points and their timing relationships. The individual waveforms have limited value unless their timing relationship to one or more of the other waveforms is known to be correct. The dual-trace oscilloscope allows this comparison to be made. In typical fashion, waveform No. 3 would be displayed on Channel A and waveform No. 4 thru No. 8, and No. 10, would be successively displayed on Channel B, although other timing comparisons may be desired. Waveforms No. 11 through No. 13 would probably be displayed on Channel B in relationship to waveform No. 8 or No. 4 on Channel A.

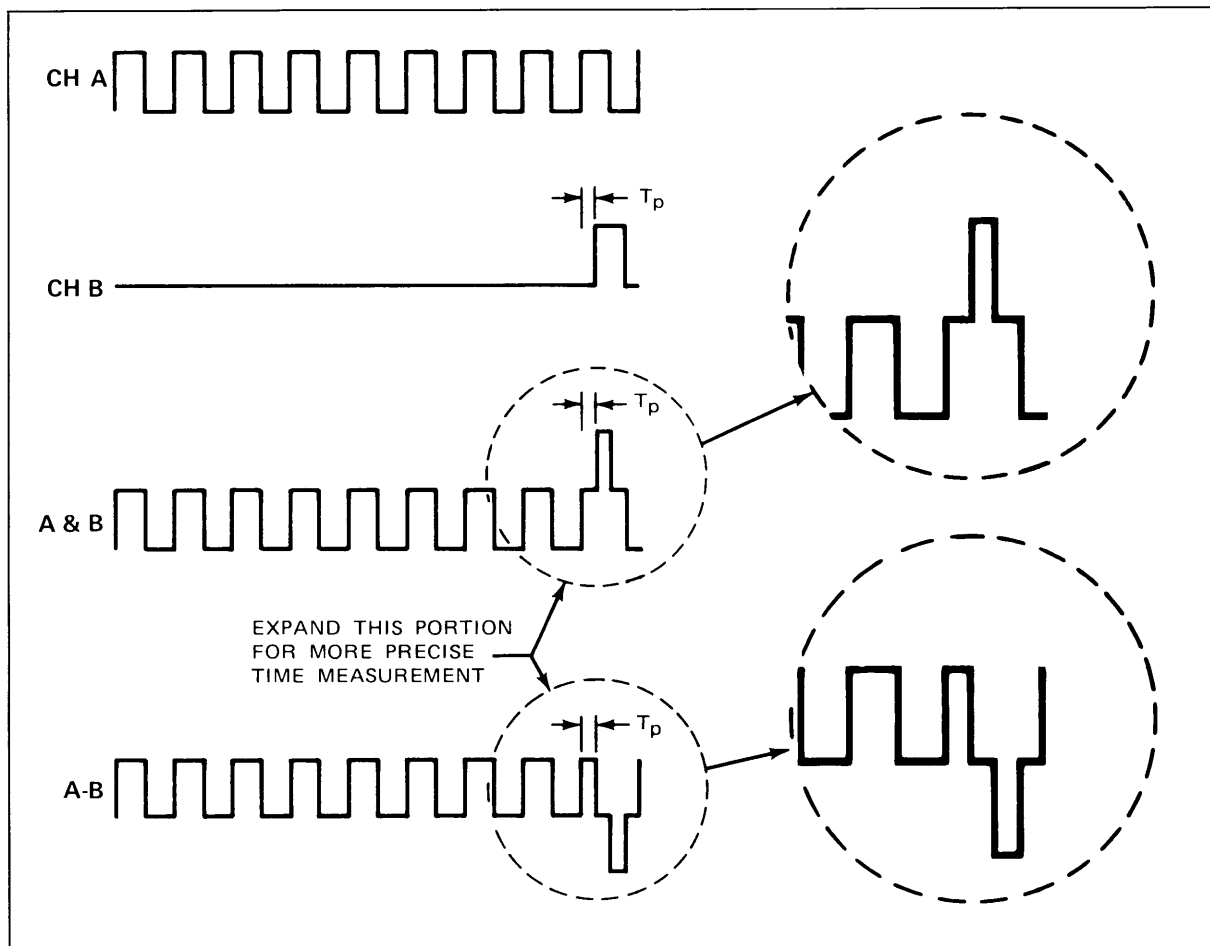

Fig. 10. Using A+B or A-B modes for propagation time measurement.

In the family of time-related waveforms shown in Fig. 12, waveform No. 8 or No. 10 is an excellent sync source for viewing all of the waveforms; there is but one triggering pulse per frame. For convenience, external sync using waveform No. 8 or No. 10 as the sync source may be desirable. With external sync, any of the waveforms may be displayed without readjustment of the sync controls. Waveforms No. 4 thru No. 7 should not be used as the sync

source because they do not contain a triggering pulse at the start of the frame. It would not be necessary to view the entire waveforms as shown in Fig. 12 in all cases. In fact, there are many times when a closer examination of a portion of the waveforms would be appropriate. In such cases, it is recommended that the sync remain unchanged while the sweep speed or 5X magnification be used to expand the waveform display.

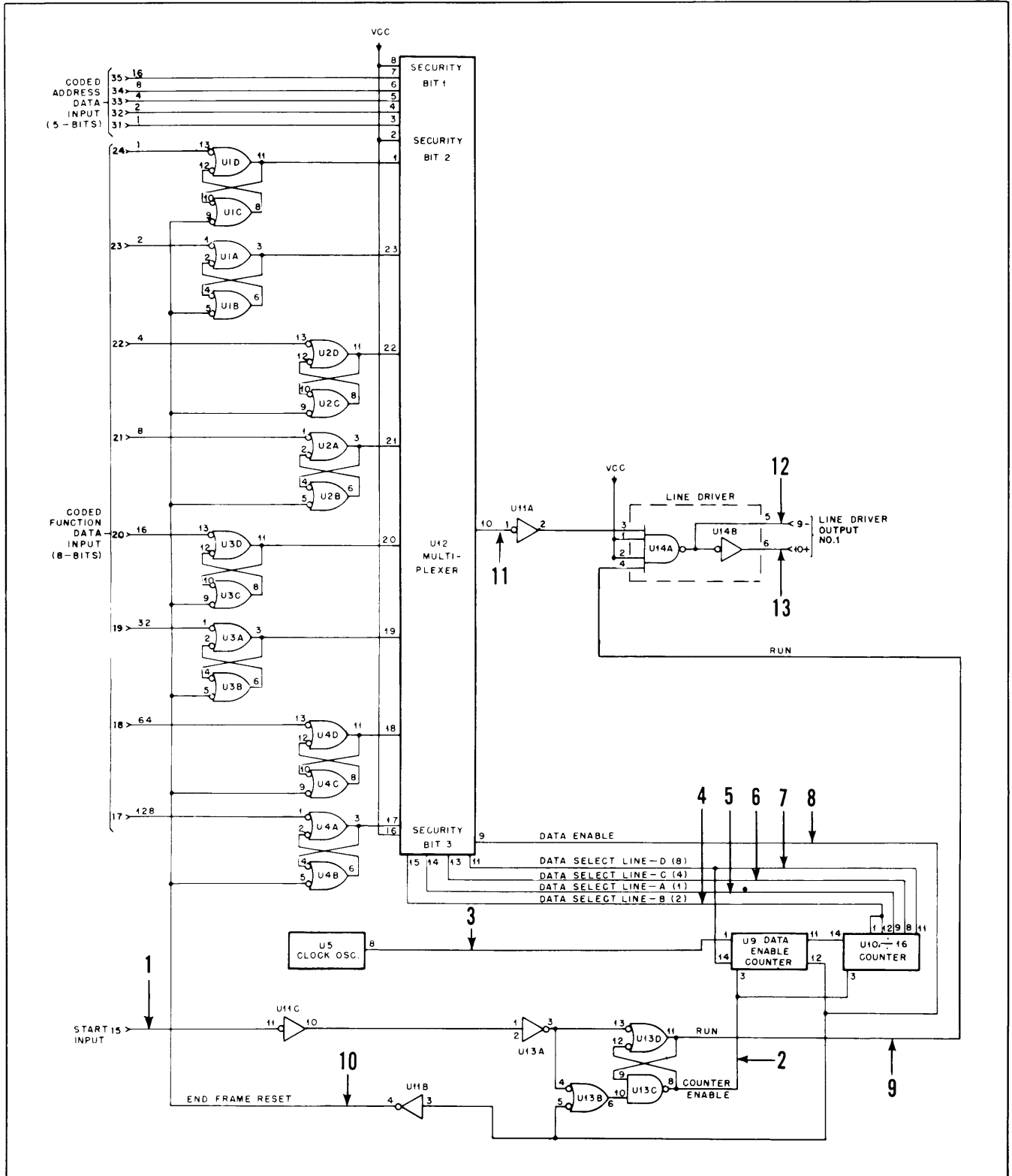

Fig. 11. Typical digital circuit using several time-related waveforms.

DISTORTION MEASUREMENT

An amplifier stage, or an entire amplifier unit, may be tested for distortion with this oscilloscope. This type of measurement is especially valuable when the slope of a waveform must be faithfully reproduced by an amplifier. Fig. 13 shows the testing of such a circuit using a triangular wave, such as is typically encountered in the recovered audio output of a limiting circuit which precedes the modulator of a transmitter. The measurement may be made using any type of signal; merely use the type of signal for testing that is normally applied to the amplifier during normal operation. The procedure for distortion testing follows:

1. Apply the type of signal normally encountered in the amplifier under test.
2. Connect Channel A probe to the input of the amplifier and Channel B probe to the output of the amplifier. It is preferable if the two signals are not inverted in relationship to each other, but inverted signals can be used.
3. Set CH A and CH B DC-GND-AC switches to AC.
4. Set MODE switch to A & B.
5. Set sync SLOPE switch to CH A and adjust controls as described in waveform viewing procedure. for synchronized waveforms.
6. Adjust the CH A and CH B POSITION controls to superimpose the waveforms directly over each other.
7. Adjust the CH A and CH B vertical sensitivity controls (VOLTS/CM and VARIABLE) so that the waveforms are as large as possible without exceeding the limits of the scale, and so that both waveforms are exactly the same height.
8. Now set the MODE switch to the A-B position (if one waveform is inverted in relationship to the other, use the A+B position). Adjust the fine vertical sensitivity (CH B VARIABLE) slightly for the minimum remaining waveform. Any waveform that remains equals distortion; if the two waveforms are exactly the same amplitude and there is no distortion, the waveforms will cancel and there will be only a straight horizontal line remaining on the screen.

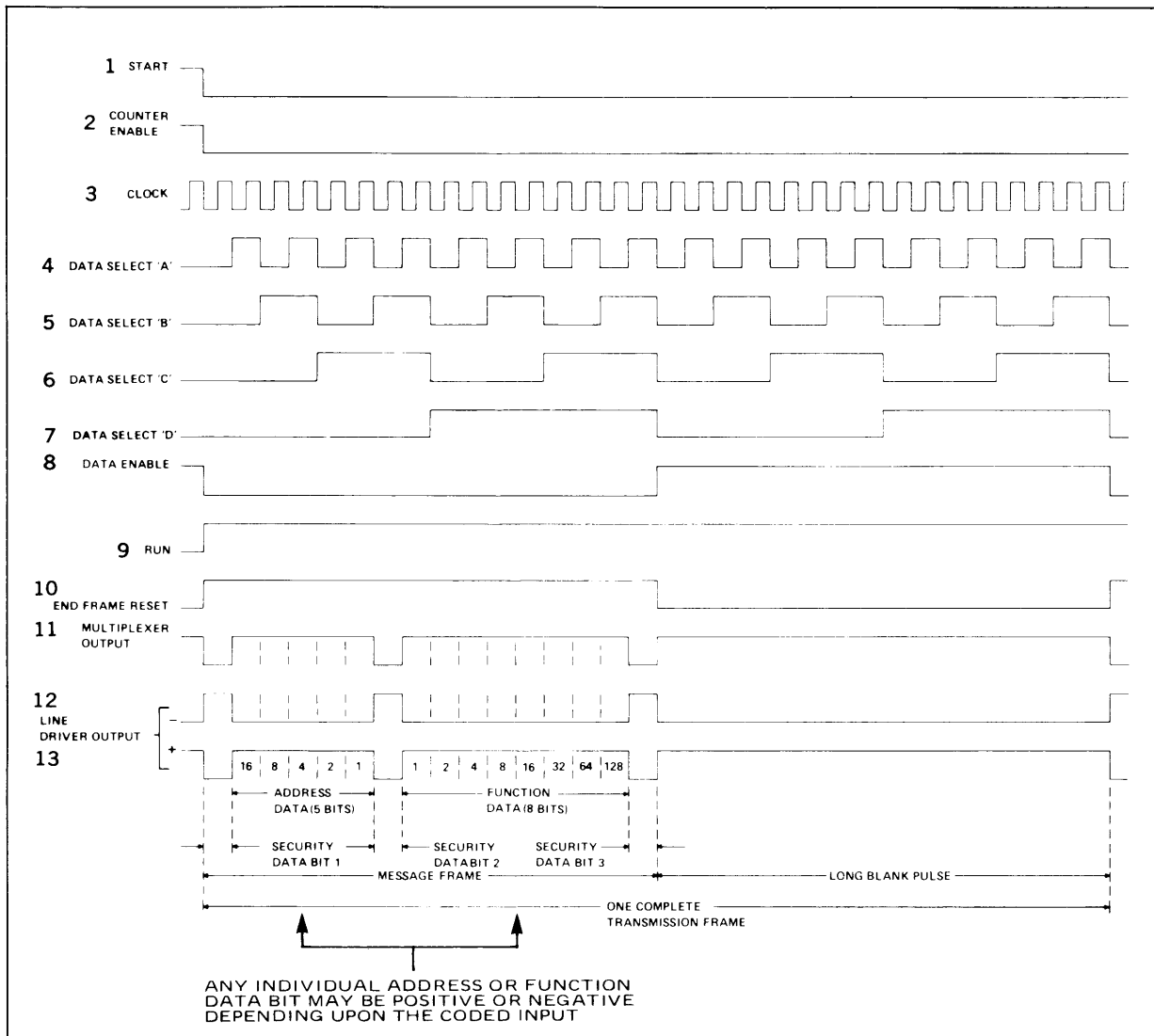

Fig. 12. Family of time-related waveforms from typical digital circuit in Fig. 11.

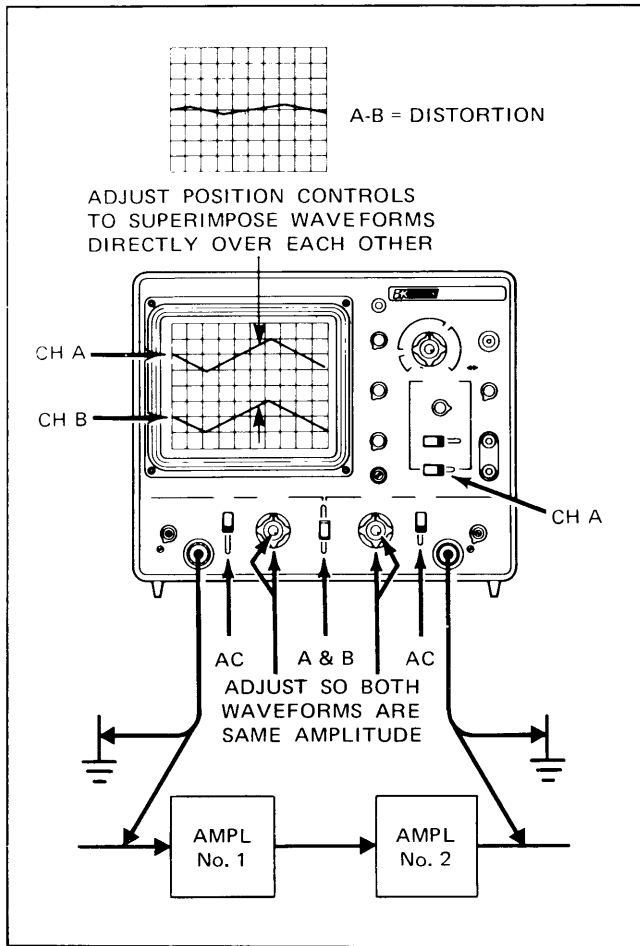

Fig. 13. Distortion measurement.

GATED RINGING CIRCUIT

The circuit and waveforms of Fig. 14 are shown to demonstrate the type of circuit in which the dual-trace oscilloscope is effective both in design and troubleshooting applications. The basic oscilloscope control settings are identical to those of Fig. 8. Waveform A is the reference waveform and is applied to Channel A input. All other waveforms are sampled at Channel B and compared to the reference waveform of Channel A. The frequency burst signal can be examined more closely either by increasing the sweep time per centimeter to .5 mSEC per centimeter or by pulling out on the \blacktriangleleft POSITION control to obtain 5 times magnification. This control can then be rotated as desired to center the desired waveform information on the oscilloscope screen.

DELAY LINE TESTS

The dual-trace feature of the oscilloscope can also be used to determine the delay times of transmission type delay lines as well as ultrasonic type delay lines. The input pulse can be used to trigger or synchronize the Channel A display and the delay line output can be observed on Channel B. A repetitive type pulse will make it possible to synchronize the displays. The interval between repetitive pulses should be large compared to the delay time to be investigated. In addition to determining delay time, the pulse distortion inherent in the delay line can be determined by examination of the delayed pulse observed on the Channel B waveform display. Figure 15 demonstrates the typical oscilloscope settings as well as the basic test circuit.

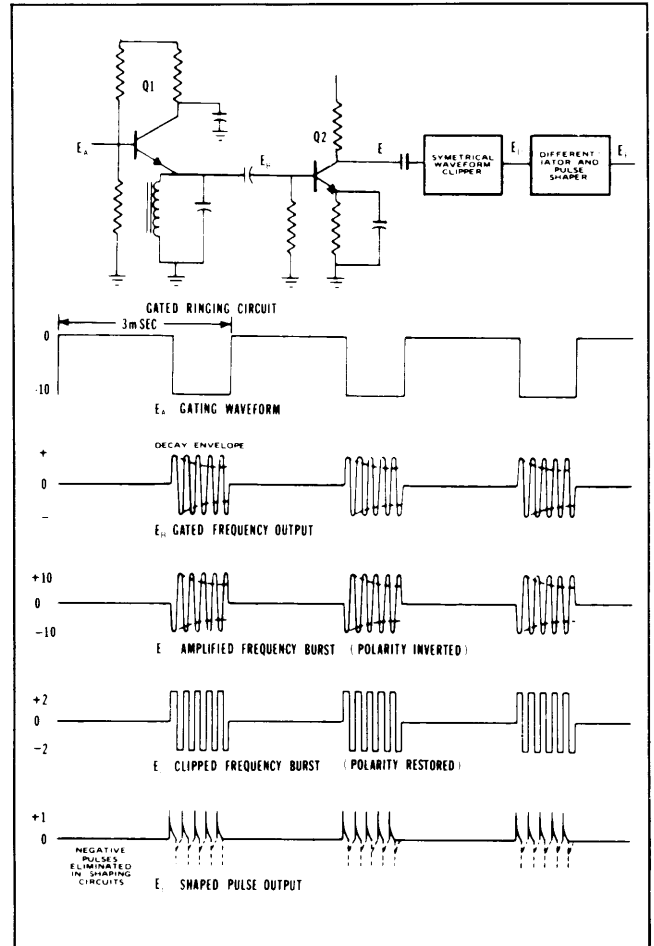

Fig. 14. Gated ringing circuit and waveforms.

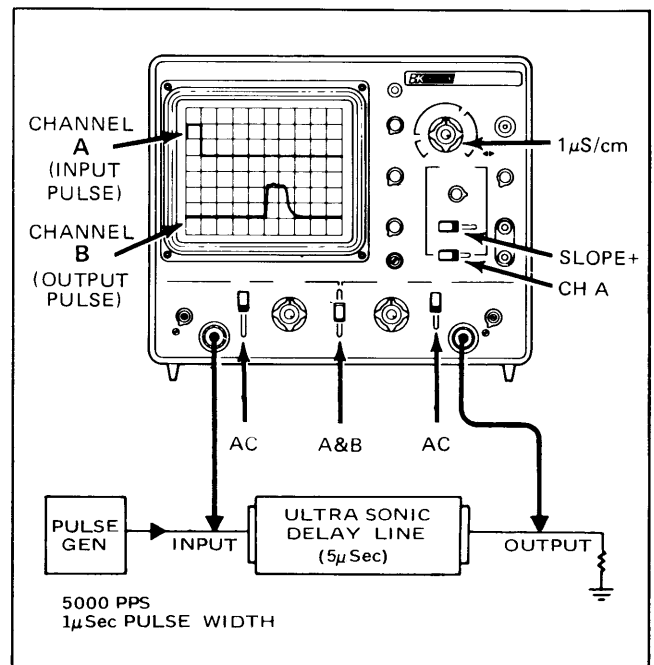

Fig. 15. Delay line measurements.

Typical input and output waveforms are shown on the oscilloscope display. Any pulse stretching and ripple can be observed and evaluated. The results of modifying the input and output terminations can be observed directly.

A common application of the delay line checks is found in color television receivers. Figure 16 shows the oscilloscope settings and typical circuit connections to check the "Y" delay line employed in the video amplifier section. The input waveform and the output waveform are compared for delay time, using the horizontal sync pulse of the composite video signal for reference. The indicated delay is approximately one microsecond. In addition to determining the delay characteristics of the line, the output waveform reveals any distortion that may be introduced from an impedance mismatch or a greatly attenuated output resulting from an open line.

STEREO AMPLIFIER SERVICING

Another convenient use for dual-channel oscilloscopes is in troubleshooting stereo amplifiers. If identical channel amplifiers are used and the output of one is weak, distorted or otherwise abnormal, the dual trace oscilloscope can be efficiently used to localize the defective state. With an identical signal applied to the inputs of both amplifiers, a side-by-side comparison of both units can be made by progressively sampling identical signal points in both amplifiers. When the defective or malfunctioning stage has been located, the effects of whatever troubleshooting and repair methods are employed can be observed and analyzed immediately.

IMPROVING THE RATIO OF DESIRED TO UNDESIRE SIGNALS

In some applications, the desired signal may be riding on a large undesired signal component such as 60 Hz. It is possible to minimize or for practical purposes eliminate the undesired component. Fig. 17 indicates the oscilloscope control settings for such an application. The waveform display of Channel A indicates the desired signal and the dotted line indicates the average amplitude variation corresponding to an undesired 60 Hz component. The Channel B display indicates a waveform of equal amplitude and identical phase to the average of the Channel 1 waveform. With the MODE switch set to A-B, and by adjusting the CH B vertical attenuator controls, the 60 Hz component of the Channel A signal can be cancelled by the Channel B input and the desired waveform can be observed without the 60 Hz component.

AMPLIFIER PHASE SHIFT MEASUREMENTS

In the single-trace application section of this manual phase shift measurements using a single trace are described. In addition, in the square wave testing section, square wave distortion is explained in terms of phase shift of the signal components which comprise the square wave. These phase shifts can be verified directly by providing a sine wave input signal to the amplifier and observing the phase of the output signal with respect to the input signal.

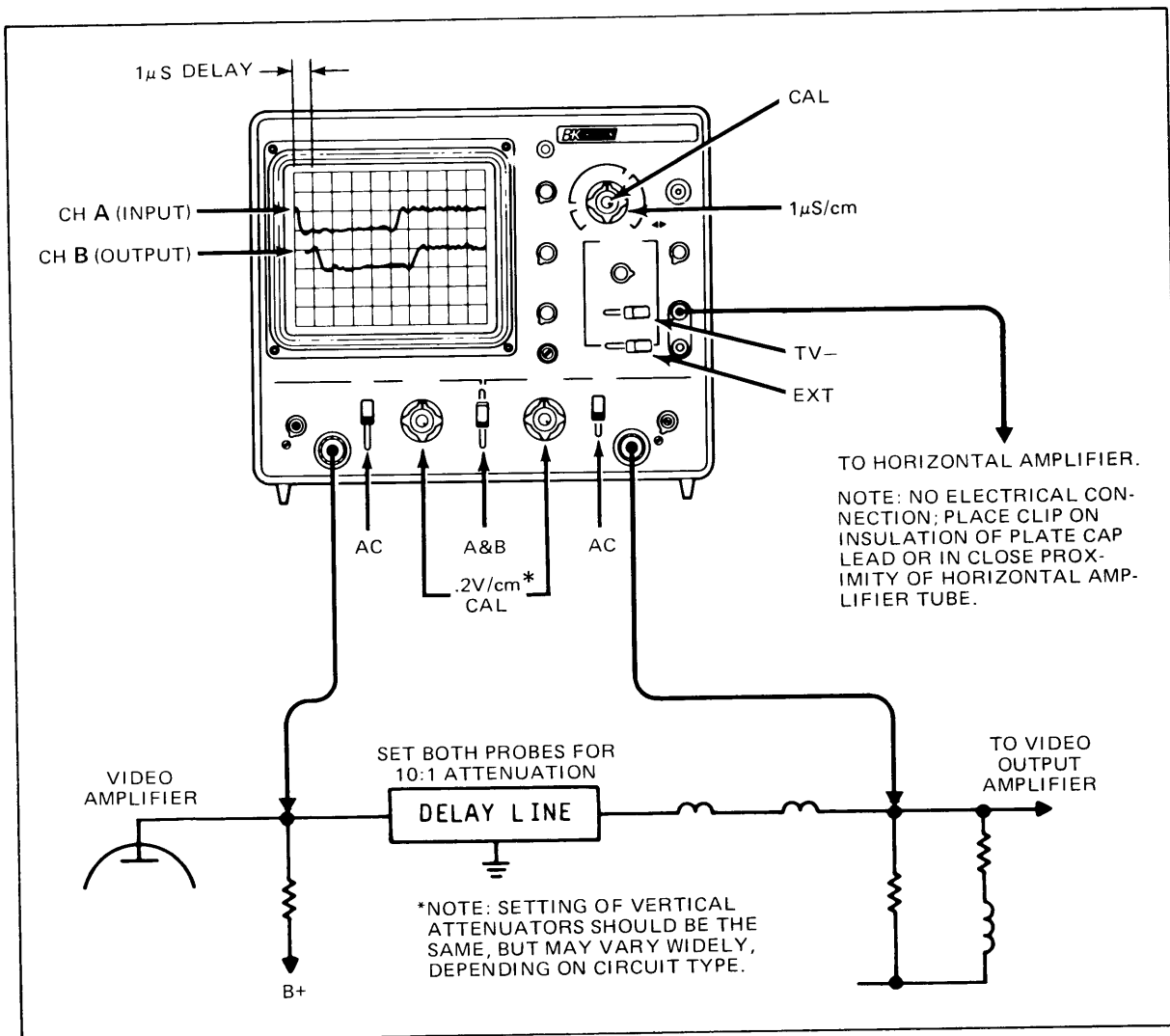

Fig. 16. Checking "Y" delay line in color television receivers.

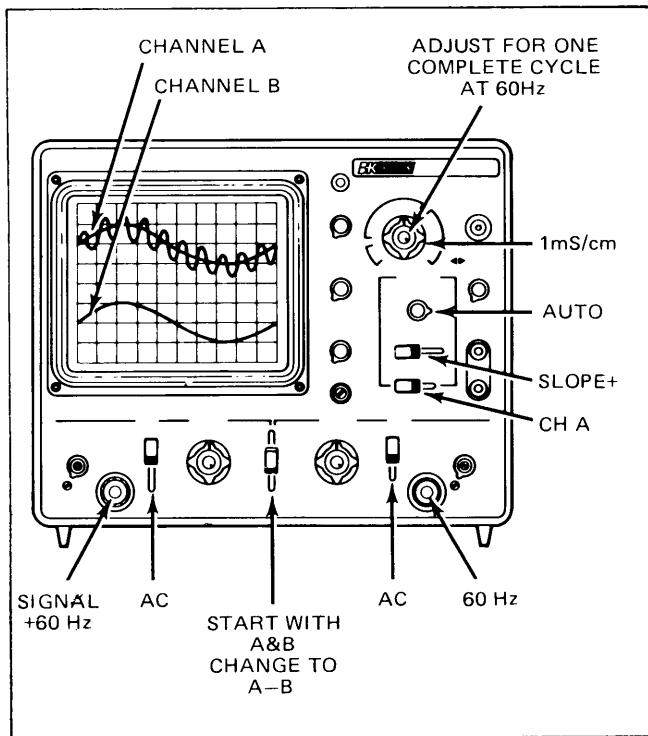

Fig 17. Improving desired-to-undesired signal ratio.

In all amplifiers, a phase shift is always associated with a change in amplitude response. For example, at the -3 dB response points, a phase shift of 45° occurs. Fig. 18 illustrates a method of determining amplifier phase shift directly. In this particular case, the measurements are being made at approximately 5000 Hz. The input signal to the audio amplifier is used as a reference and is applied to the CH A INPUT jack.

The VARIABLE control is adjusted as required to provide a complete cycle of the input waveform displayed

on 8 cm horizontally. A waveform height of 2 cm is used. The 8 cm display represents 360° at the displayed frequency and each centimeter represents 45° of the waveform. The signal developed across the output of the audio amplifier is applied to the Channel B INPUT jack. The vertical attenuator controls of Channel B are adjusted as required to produce a peak-to-peak waveform of 2 cm as shown in Fig. 18B.

The CH B POSITION control is then adjusted so that the Channel B waveform is displayed on the same horizontal axis as the Channel A waveform as shown in Fig. 18B. The distance between corresponding points on the horizontal axis for the two waveforms then represents the phase shift between the two waveforms. In this case, the zero crossover points of the two waveforms are compared. It is shown that a difference of 1 centimeter exists. This is then interpreted as a phase shift of 45° .

TELEVISION SERVICING

Many of the television servicing procedures can be performed using single-trace operation. These are outlined later in the applications section covering single-trace operation. One of these procedures, viewing the VITS (vertical interval test signal), can be accomplished much more effectively using a dual-trace oscilloscope. As outlined in the single-trace applications section and as shown in Fig. 25 and 26, the information on the Field #1 and Field #2 vertical blanking interval pulse is different. This is shown in detail in Fig. 25. Also, because the oscilloscope sweep is synchronized to the vertical blanking interval waveform, the Field #1 and Field #2 waveforms are superimposed onto each other as shown in Fig. 27A. With dual-trace operation, the signal information on each blanking pulse can be viewed separately without overlapping. Fig. 19 indicates the oscilloscope control setting for viewing the alternate VITS.

1. The color television receiver on which the VITS information is to be viewed must be set to a station transmitting a color broadcast.

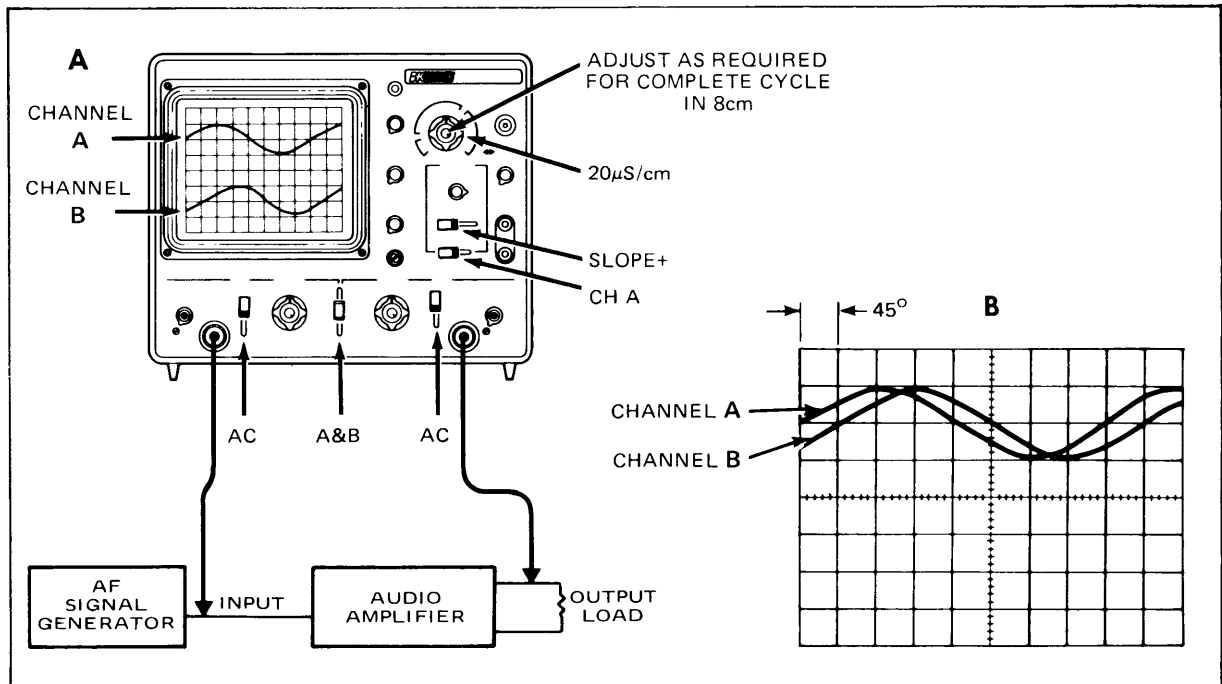

Fig. 18. Measuring amplifier phase shift.

2. The control settings of Fig. 19 are those required to obtain a 2-field vertical display on Channel A.
3. With the oscilloscope and television receiver operating, connect the Channel A probe (set at 10:1) to the video detector test point.
4. Set the SYNC switch as follows:
 - A. If the sync and blanking pulses of the observed video signal are positive; use the TV+ switch position.
 - B. If the sync and blanking pulses are negative, use the TV- switch position.
5. Adjust the sweep time VARIABLE control so that 2 vertical fields are displayed on the oscilloscope screen.
6. Connect the Channel B probe (set to 10:1) to the video detector test point.
7. Set the MODE switch to the A & B position. Identical waveform displays should now be obtained on Channels A and B.
8. Place the sweep time VARIABLE control in the CAL position.
9. Set the SWEEP TIME/CM control to the .1mS/CM position. This expands the display by increasing the sweep speed. The VITS information will appear toward the right hand portion of the expanded waveform displays. The waveform information on each trace may appear as shown in the drawing of Fig. 26. Because there is no provision for synchronizing the oscilloscope

display to either of the two fields which comprise a complete vertical frame, it cannot be predicted which field display will appear on the Channel A or Channel B display.

10. Pull the ◀ POS control outward to obtain an additional 5X magnification. Rotate the control in a counterclockwise direction moving the traces to the left until the expanded VITS information appears as shown in Fig. 20.

NOTE

Because of the low repetition rate and the high sweep speed combination, the brightness level of the signal displays will be reduced.

11. Once the Channel A and Channel B displays have been identified as being either Field #1 or Field #2 VITS information, the probe corresponding to the waveform display which is to be used for signal-tracing and troubleshooting can be used, and the remaining probe should be left at the video detector test point to insure that the sync signal is not interrupted. If the sync signal is interrupted, the waveform displays may reverse because, as previously explained, there is no provision in the oscilloscope to identify either of the two vertical fields which comprise a complete frame.

Fig. 20 shows the dual-trace presentation of the Field #1 and Field #2 VITS information. The Field #1 information is displayed on the trace.

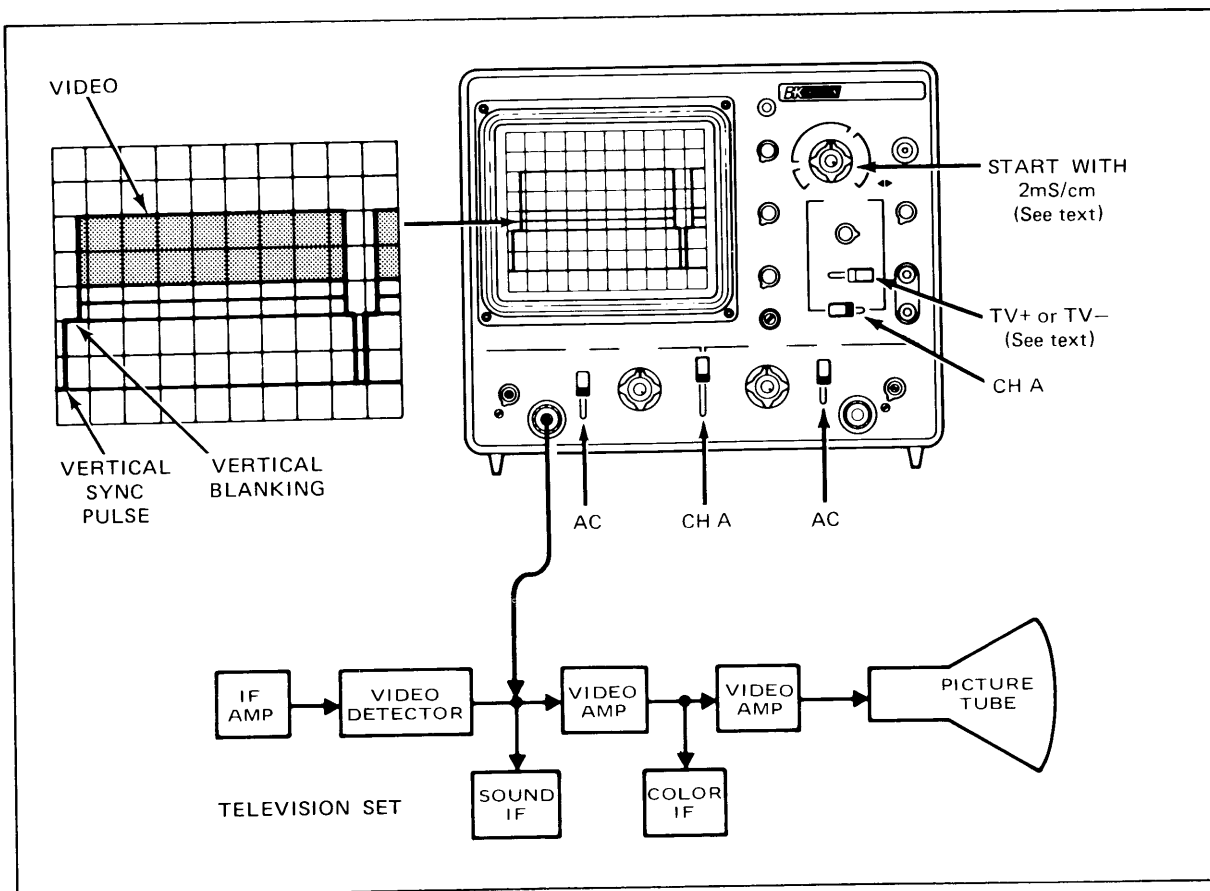

Fig. 19. Set-up for viewing fields 1 and 2 of VITS information.

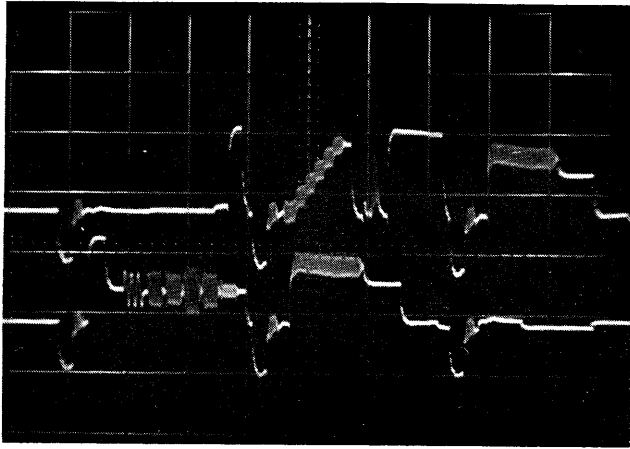

Fig. 20. Oscilloscope presentation of fields 1 and 2 of VITS information.

SINGLE-TRACE APPLICATIONS

INTRODUCTION

In addition to the dual-trace applications previously outlined, there are, of course, many service and laboratory applications where only single-trace operation of the oscilloscope is required. After gaining experience with the oscilloscope, the user will be able to make the judgment as to whether a job can be performed more efficiently by using the single-trace or the dual-trace method of operation. The following are applications in which single-trace operation is adequate. In several cases, it will be found that an alternate method using the dual-trace application has been described for the same application. For all the following applications the most flexible operation will be achieved if the Channel B vertical amplifier is used with the MODE switch in the CH B position. This arrangement provides complete triggered sweep as well as free running operation of the oscilloscope, and, in addition, by placing the MODE switch in the A-B position (with the CH A DC-GND-AC switch in the GND position), whatever waveform is obtained can be inverted in polarity if desired by the operator.

TELEVISION SERVICING

A triggered sweep oscilloscope is advantageous in servicing and aligning television receivers. This oscilloscope also includes several features that were incorporated to make television servicing easier and more comprehensive. These features include:

- SWEEP TIME/CM control automatically selects vertical sync at sweep speeds appropriate for viewing frames and horizontal sync at sweep speeds appropriate for viewing lines.
- Vector overlay for color demodulator checks.
- Wide bandwidth for high resolution video and pulse presentation.

SIGNAL-TRACING AND PEAK-TO-PEAK VOLTAGE READINGS

For general troubleshooting and isolation of troubles in television receivers (or almost any other electronic equipment for that matter), the oscilloscope is an indispensable instrument. It provides a visual display of absence or

presence of normal signals. This method (signal-tracing) may be used to trace a signal by measuring several points in the signal path. As measurements proceed along the signal path, a point may be found where the signal disappears. When this happens, the source of trouble has been located.

However, the oscilloscope shows much more than the mere presence or absence of signal. It provides a peak-to-peak voltage measurement of the signal. The cause of poor performance can often be located by making such peak-to-peak voltage measurements. The schematic diagram or accompanying service data on the equipment being serviced usually includes waveform pictures. These waveform pictures include the required sweep time and the normal peak-to-peak voltage. Compare the peak-to-peak voltage readings on the oscilloscope with those shown on the waveform pictures. Any abnormal readings should be followed by additional readings in the suspected circuits until the trouble is isolated to as small an area as possible. The procedures for making peak-to-peak voltage measurements are given earlier in the CALIBRATED VOLTAGE MEASUREMENT paragraph.

COMPOSITE VIDEO WAVEFORM ANALYSIS

Probably the most important waveform in television servicing is the composite waveform consisting of the video signal, the blanking pedestals and the sync pulses. Fig. 21 and 22 show typical oscilloscope traces when observing composite video signals synchronized with horizontal sync pulses and vertical blanking pulses. Composite video signals can be observed at various stages of the television receiver to determine whether circuits are performing normally. Knowledge of waveform makeup, the appearance of a normal waveform, and the causes of various abnormal waveforms help the technician locate and correct many problems. The technician should study such waveforms in a television receiver known to be in good operating condition, noting the waveform at various points in the video amplifier.

To set up the oscilloscope for viewing television composite video waveforms, use the following procedure:

1. Tune the television set to a local channel.
2. Set the MODE switch to the CH B position.
3. Set the SWEEP TIME/CM switch to the 10 μ S/cm position for observing TV horizontal lines or to the 2 mS/cm position for observing TV vertical frames.
4. Set the SYNC switch to the TV+ position.
5. Set the SOURCE switch to the CH B position.
6. Pull the TRIGGERING LEVEL control for automatic sync.
7. Set the CH B DC-GND-AC switch to the AC position.
8. Connect a probe cable to the CH B INPUT jack. Connect the ground clip of the probe to the television set chassis. With the probe set for 10:1 attenuation, connect the tip of the probe to the video detector output of the television set.
9. Set the CH B VOLTS/CM switch for the largest vertical deflection possible without going off-scale.
10. If necessary, rotate the TRIGGERING LEVEL control to a position that provides a synchronized display.
11. Adjust the sweep time VARIABLE control for two horizontal lines or two vertical frames of composite video display.

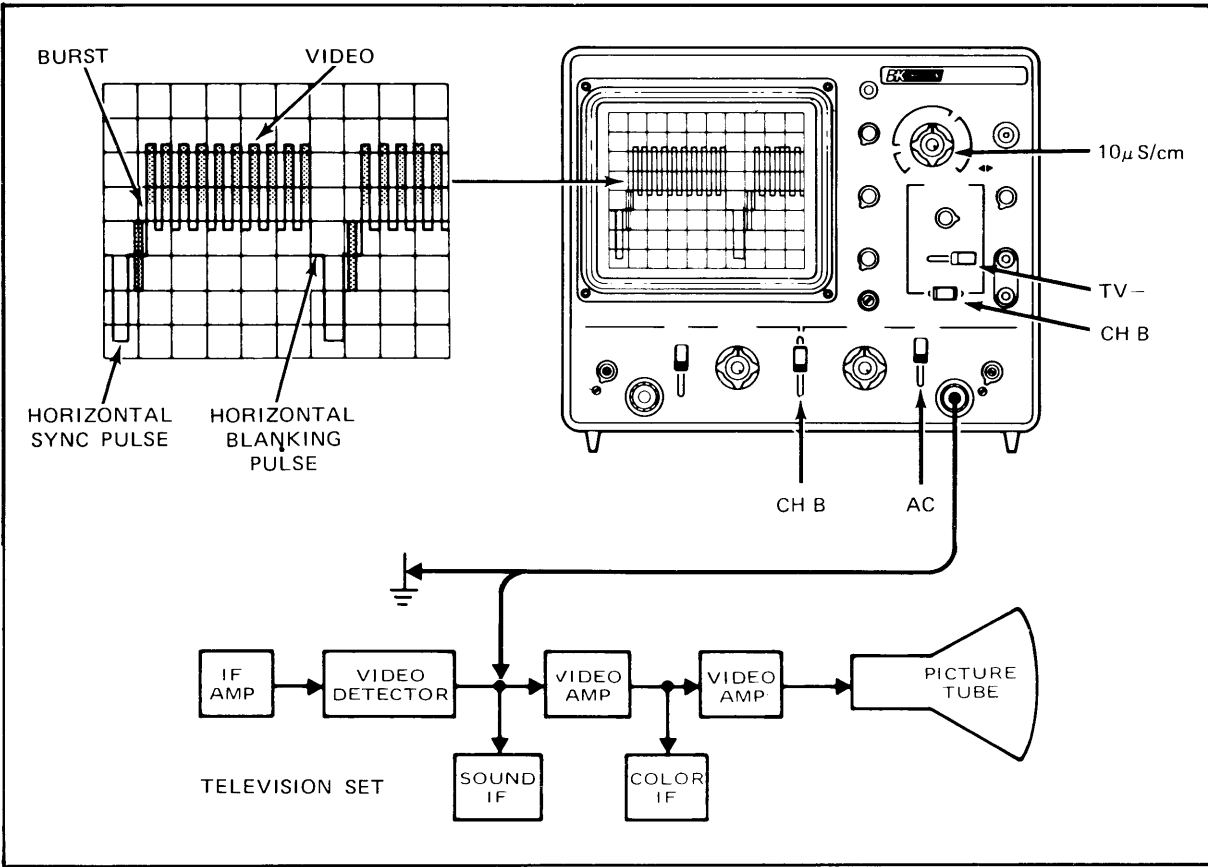

Fig. 21. Set-up for viewing *horizontal* fields of composite video signal.

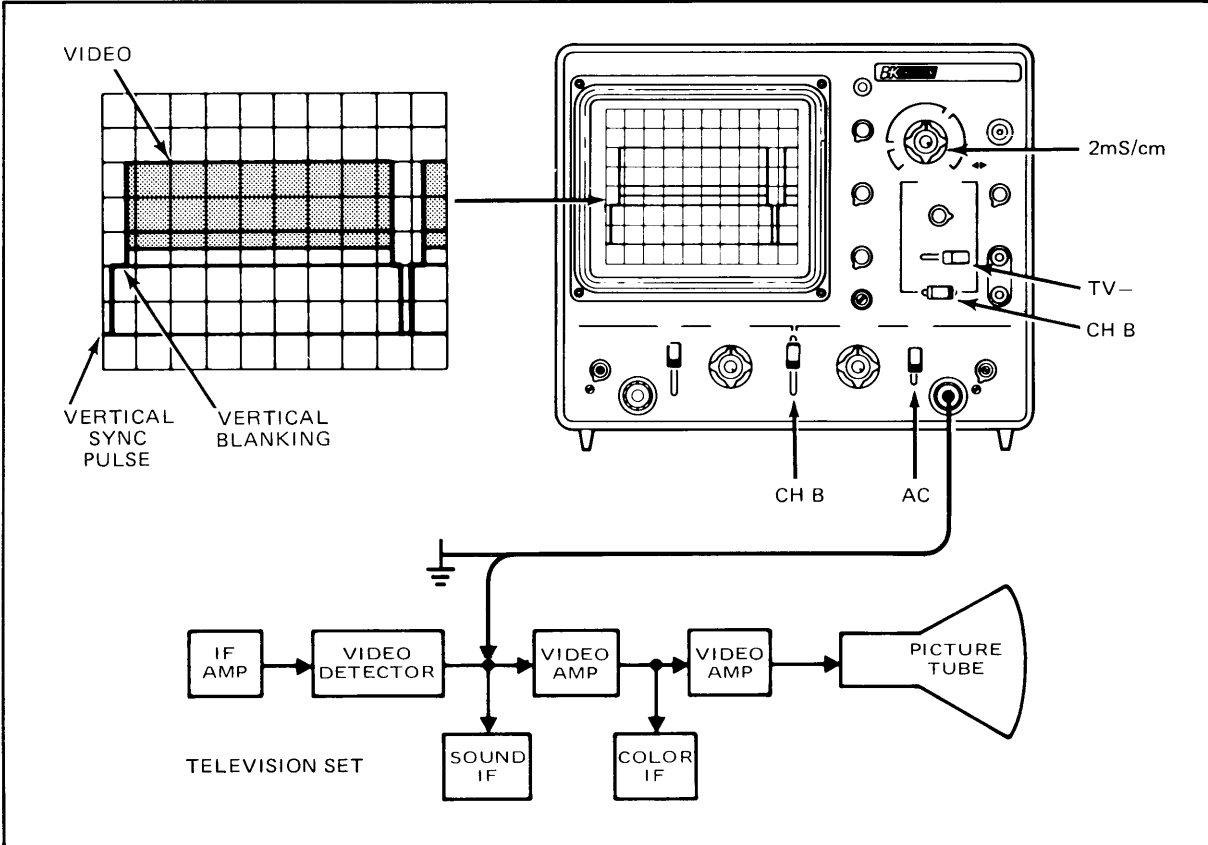

Fig. 22. Set-up for viewing *vertical* fields of composite video signal.

12. If the sync and blanking pulses of the displayed video signals are positive, set the SYNC switch to the TV+ position; if the sync and blanking pulses are negative, use the TV- position.
13. Push in the TRIGGERING LEVEL control and rotate to a position that provides a well-synchronized display.
14. Adjust the INTENSITY and FOCUS controls for the desired brightness and best focus.
15. To view a specific portion of the waveform, such as the color burst, pull outward on the ◀► POSITION control for 5X magnification. Rotate the same control left or right to select the desired portion of the waveform to be viewed.
16. Composite video waveforms may be checked at other points on the video circuits by moving the probe tip to those points and changing the VOLTS/CM control setting as required to keep the display within the limits of the scale, and by readjusting the TRIGGERING LEVEL control to maintain stabilization. The polarity of the observed waveform may be reversed when moving from one monitoring point to another; therefore, it may be necessary to reverse the polarity of the SYNC.

SYNC PULSE ANALYSIS

The IF amplifier response of a television receiver can be evaluated to some extent by careful observation of the horizontal sync pulse waveform. The appearance of the sync pulse waveform is affected by the IF amplifier bandpass characteristics. Some typical waveform symptoms and their relation to IF amplifier response are indicated in Fig. 23. Sync pulse waveform distortions produced by positive or negative limiting in IF overload conditions are shown in Fig. 24.

CIRCUIT DEFECT	HORIZONTAL PULSE DISTORTION	OVERALL RECEIVER FREQUENCY RESPONSE	EFFECT ON PICTURE
Normal Circuit			Picture Normal
Loss of high frequency response			Loss of picture detail
Excessive high frequency response, non-linear phase shift			Fine vertical black and white striations following a sharp change in picture shading
Loss of low frequency response			Change in shading of large picture areas, smeared picture

Fig. 23. Analysis of sync pulse distortion.

VITS (VERTICAL INTERVAL TEST SIGNAL)

Most network television signals contain a built-in test signal (the VITS) that can be a very valuable tool in troubleshooting and servicing television sets. This VITS can localize trouble to the antenna, tuner, IF or video sections and shows when realignment may be required. The following procedures show how to analyze and interpret oscilloscope displays of the VITS.

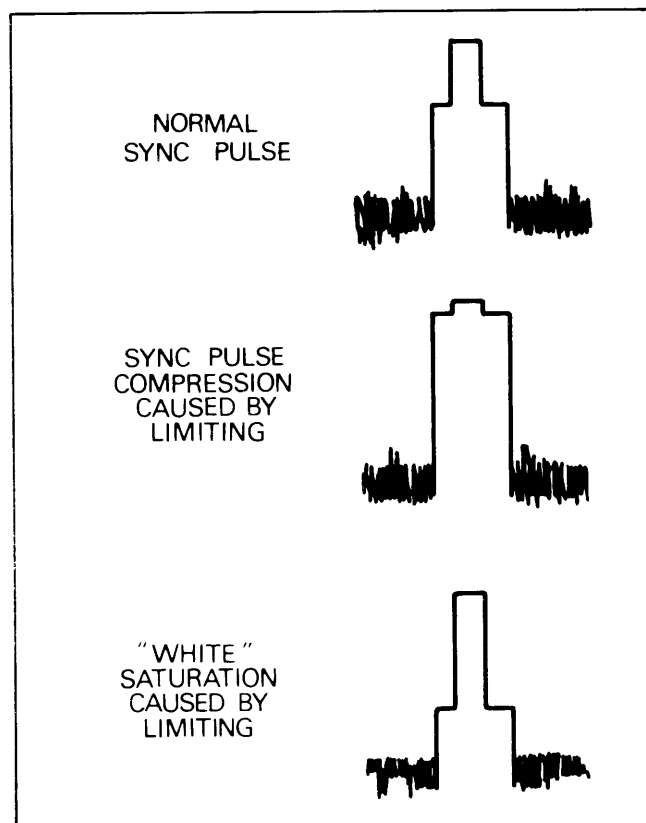

Fig. 24. Sync pulse waveforms.

The VITS is transmitted during the vertical blanking interval. On the television set, it can be seen as a bright white line above the top of the picture, when the vertical linearity or height is adjusted to view the vertical blanking interval (on TV sets with internal retrace blanking circuits, the blanking circuit must be disabled to see the VITS).

The transmitted VITS is a precision sequence of specific frequency, amplitude, and waveshape as shown in Fig. 25 and 26. The television networks use the precision signals for adjustment and checking of network transmission equipment, but the technician can use them to evaluate television set performance. The first frame of the VITS (line 17) begins with a "flag" of white video, followed by sine wave frequencies of 0.5 MHz, 1.5 MHz, 2 MHz, 3 MHz, 3.6 MHz,

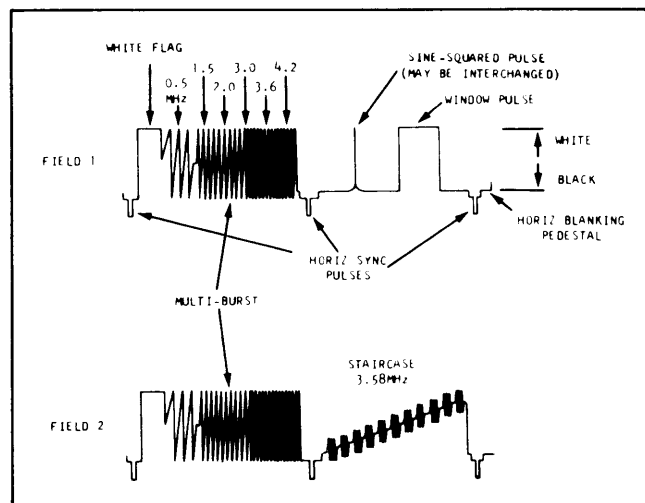

Fig. 25. VITS signal, fields 1 and 2.

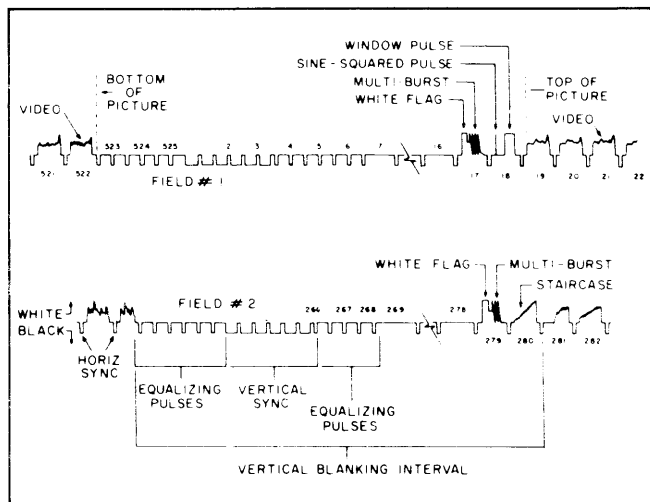

Fig. 26. Vertical blanking interval, showing VITS information.

(3.58 MHz) and 4.2 MHz. This sequence of frequencies is called the "multi-burst". The first frame of Field #2 (line 279) also contains an identical multi-burst. This multi-burst portion of the VITS is the portion that can be most valuable to the technician. The second frame of the VITS (lines 18 and 280), which contains the sine-squared pulse, window pulse and the staircase of 3.58 MHz bursts at progressively lighter shading, are valuable to the network, but have less value to the technician. As seen on the television screen, Field #1 is interlaced with Field #2 so that line 17 is followed by line 279 and line 18 is followed by line 280. The entire VITS appears at the bottom of the vertical blanking pulse and just before the first line of video.

Each of the multi-burst frequencies is transmitted at equal strength. By observing the comparative strengths of these frequencies *after* the signal is processed through the television receiver, the frequency response of the set is checked.

Set up the oscilloscope as follows to view the VITS:

1. Connect the CH B probe (set at 10:1) to the output of the video detector or other desired test point in the video section of the television set.
2. If the television set has a vertical retrace blanking circuit, bypass this circuit during the measurement.
3. Set the MODE switch to CH B.
4. Set up the oscilloscope for TV vertical composite video waveform analysis as previously described. Two vertical frames will be visible.
5. Place the sweep time VARIABLE control in the CAL position.
6. Reduce sweep time to .1 millisecond per centimeter (.1 ms/CM) with the SWEEP TIME/CM switch. This expands the display by increasing the sweep speed. The VITS information will appear to the right on the expanded waveform display.
7. Further expand the sweep with the 5X magnification (pull outward on the ◀ POSITION control). Rotate the ▶ POSITION control in a counterclockwise direction, moving the trace to the left, until the expanded VITS appears.

NOTE

The brightness level of the signal display will be reduced because, although the repetition rate is only 60 Hz (a 16,000 μ SEC period) the writing speed is 20 μ SEC/cm (.1 mSEC/cm magnified five times).

8. The waveform should be similar to that shown in Fig. 27. For the oscilloscope display, each vertical sync pulse starts a new sweep. This causes line 17 and line 279 (multi-burst) to be superimposed, as are lines 18 and 280. The multi-burst signals are identical, which reinforces the trace. However, lines 18 and 280 are not identical and both signals are superimposed over each other.

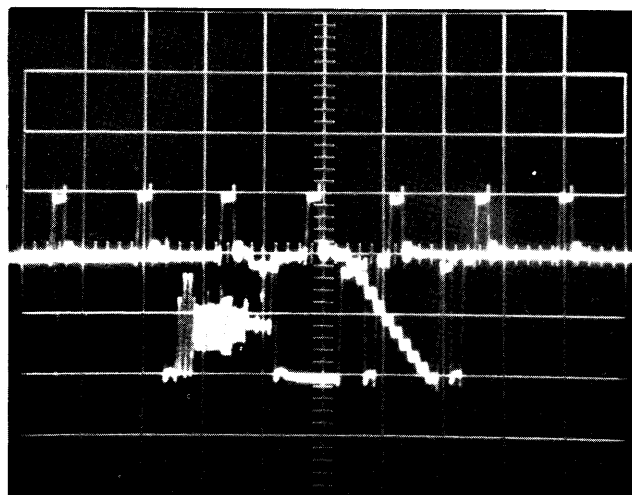

Fig. 27. Oscilloscope presentation of VITS information, single-trace operation.

9. The presentation of the preceding paragraphs (Fig. 27) is the limit of observation possible with a single-trace oscilloscopy. With the Model 1472C oscilloscope, however, a single-field VITS presentation can be obtained by placing the MODE switch in the A & B position. This causes the Channel B information to be displayed on alternate sweeps, as are the Field #1 and Field #2 VITS. Because there is no provision for preselecting the Field #1 or Field #2 information, either Field #1 or Field #2 (Fig. 22) will appear. The multi-burst information in the VITS is the most valuable for troubleshooting television receivers and, because it is present on both Field #1 and Field #2 VITS, either can be used for troubleshooting and signal tracing.

Now to analyze the waveform. All frequencies of the multi-burst are transmitted at the same level, but should not be equally coupled through the receiver due to its response curve. Fig. 28 shows the desired response for a good color television receiver, identifying each frequency of the multi-burst and showing the allowable amount of attenuation for each. Remember that -6 dB equals half the reference voltage (the 2.0 MHz modulation should be used for reference).

To localize trouble, start by observing the VITS at the video detector. This will localize trouble to a point either before or after the detector. If the multi-burst is normal at the detector, check the VITS on other channels. If some channels look okay but others do not, you probably have tuner or antenna-system troubles. Don't overlook the

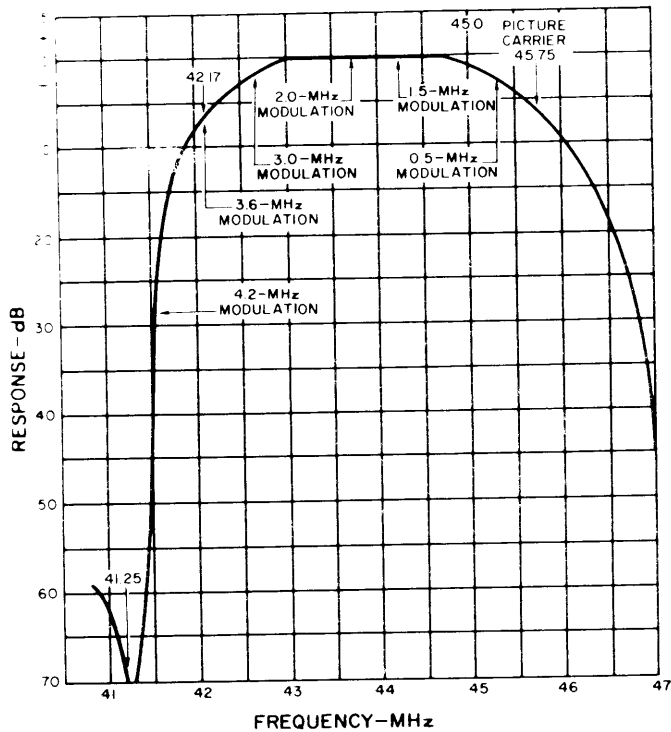

Fig. 28. Color TV IF amplifier response curve.

chance of the antenna system causing "holes" or tilted response on some channels. If the VITS is abnormal at the video detector on all channels, the trouble is probably in the IF amplifier stages.

As another example, let us assume that we have a set on the bench with a very poor picture. Our oscilloscope shows the VITS at the video detector to be about normal except that the burst at 2.0 MHz is low compared to the bursts on either side. This suggests an iF trap is detuned into the passband, chopping out frequencies about 2 MHz below the picture carrier frequency. Switch to another channel carrying VITS. If the same thing is seen, then our reasoning is right, and the IF amplifier requires realignment. If the poor response at 2 MHz is not seen on other channels, maybe an FM trap at the tuner input is misadjusted, causing a bite on only one channel. Other traps at the input of the set could similarly be misadjusted or faulty.

If the VITS response at the detector output is normal for all channels, the trouble will be in the video amplifier. Look for open peaking coils, off-value resistors, solder bridges across foil patterns, etc.

VECTORSCOPE OPERATION

Performance testing and adjustment of the color circuits in color television receivers is simplified by using the vectorscope operation of the oscilloscope. The additional equipment needed is a color bar generator. The B & K-Precision color bar generators are ideally suited for this.

First the horizontal and vertical gain of the oscilloscope must be equalized (see Fig. 30).

1. Attach vector overlay to scope. Pull off bezel, insert overlay, re-attach bezel. (Refer to MAINTENANCE AND CALIBRATION section for graticule removal.)
2. Connect the color bar generator to the television set and tune in the color bar pattern.

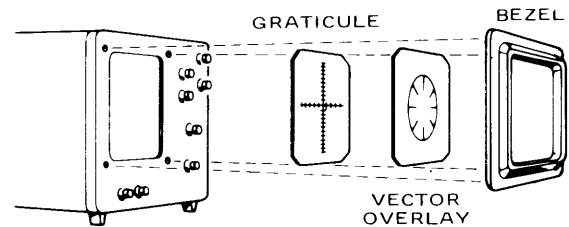

Fig. 29. Installation of vector overlay.

3. Adjust the television set's hue and brilliance controls to mid-range.
4. Set SWEEP TIME/CM control to the CH B position.
5. Connect probe cables to the CH A and CH B INPUT jacks. Channel A is the vertical input and Channel B is the horizontal input. Connect both probe tips to the driven element of the red gun, usually the grid. If the cathode is the driven element, then connect to the cathode. (The driven element is the element to which the output signal of the color amplifier is applied.)
6. Adjust the CH A (vertical gain) and CH B (horizontal gain) VOLTS/CM and VARIABLE controls to obtain a compressed 45° pattern that approximately fills the vector overlay. The oscilloscope is now set up for vectorscope operation.
7. For vector presentation, merely move the horizontal probe to the driven element of the blue gun. The color vector pattern is the same type as given by the television set manufacturer. Fig 31 shows typical displays obtained for sets using 105° systems and 90° systems with either grid drive or cathode drive.

NOTE

If the picture tube uses cathode drive, the burst will appear on the right side of the screen. Just rotate the vector overlay 180° so the BURST label is on the right side. The color bars will then align with the vector overlay.

The vector display provides a very quick measurement of the functions of the demodulators in a color TV set. The serviceman should familiarize himself with the effect on the pattern produced by the color controls. He should observe that the color amplitude control will vary the size of the petals but not their position. The hue control changes the position of the petals but not their amplitude. Lastly, 105° sets will have a more elliptical pattern than 90° sets. The table below lists some common troubles and their effect on the pattern.

The vector display can be used to check the range of the color set's hue control. It should be possible to rotate the R-Y petal about the vertical axis. At the center of the hue control the R-Y petal should be vertical. If it is not, locate the CHROMA reference oscillator. In most sets this oscillator is transformer-coupled to the demodulators.

A slight touch-up of this transformer is all that is necessary to bring the R-Y petal to a vertical position. Do not attempt to make any adjustments on the chroma bandpass amplifiers. This

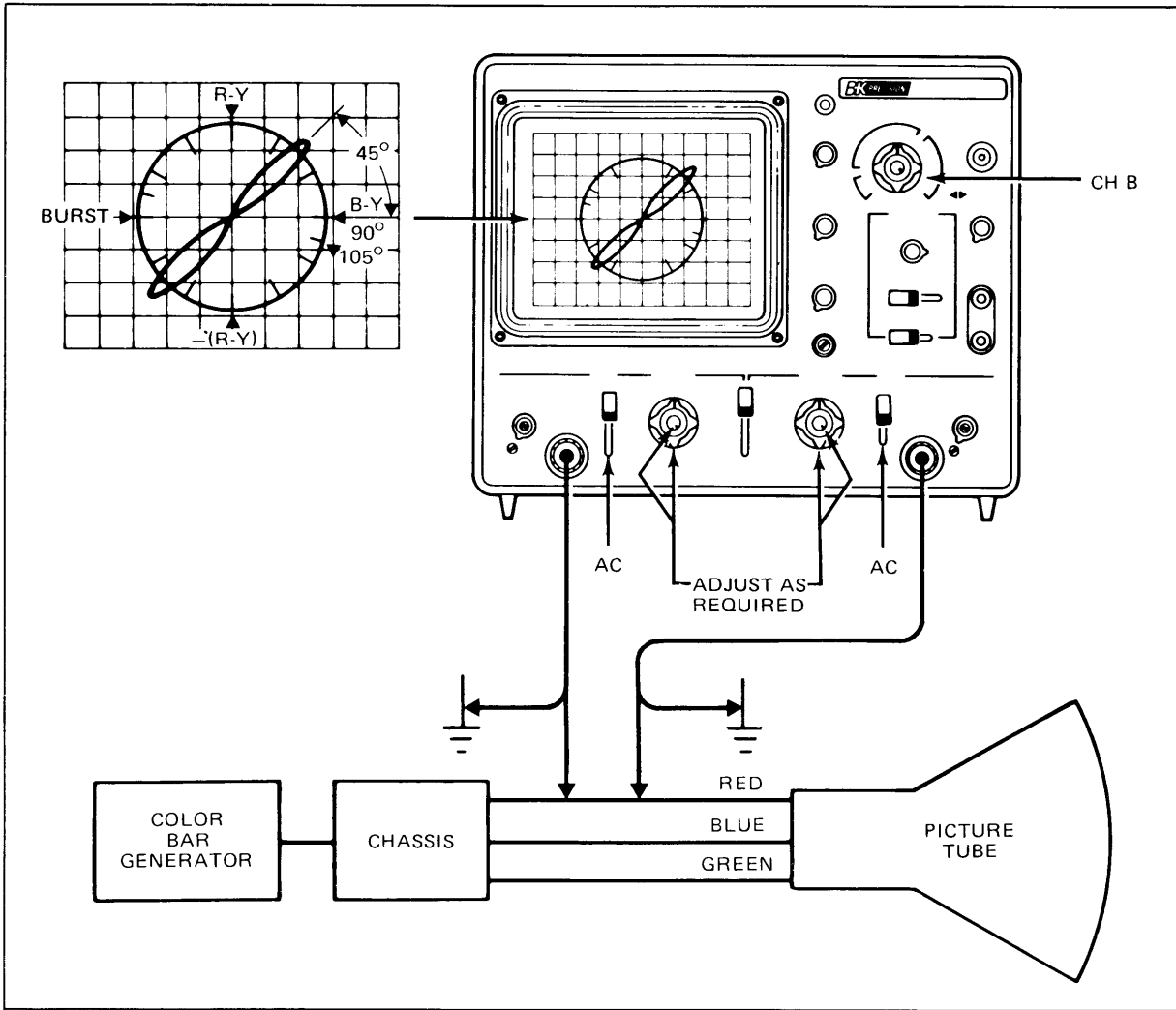

Fig. 30. Equalizing horizontal and vertical gain for Vectorscope operation.

amplifier is aligned by a sweep generator and cannot in general be aligned by just a vector display.

If the set has adjusted demodulators, the vector display can also be used for demodulator alignment. Follow the manufacturer's alignment procedure to locate the proper coils and instead of counting bars simply adjust for the correct angle between R-Y and B-Y.

NOTES

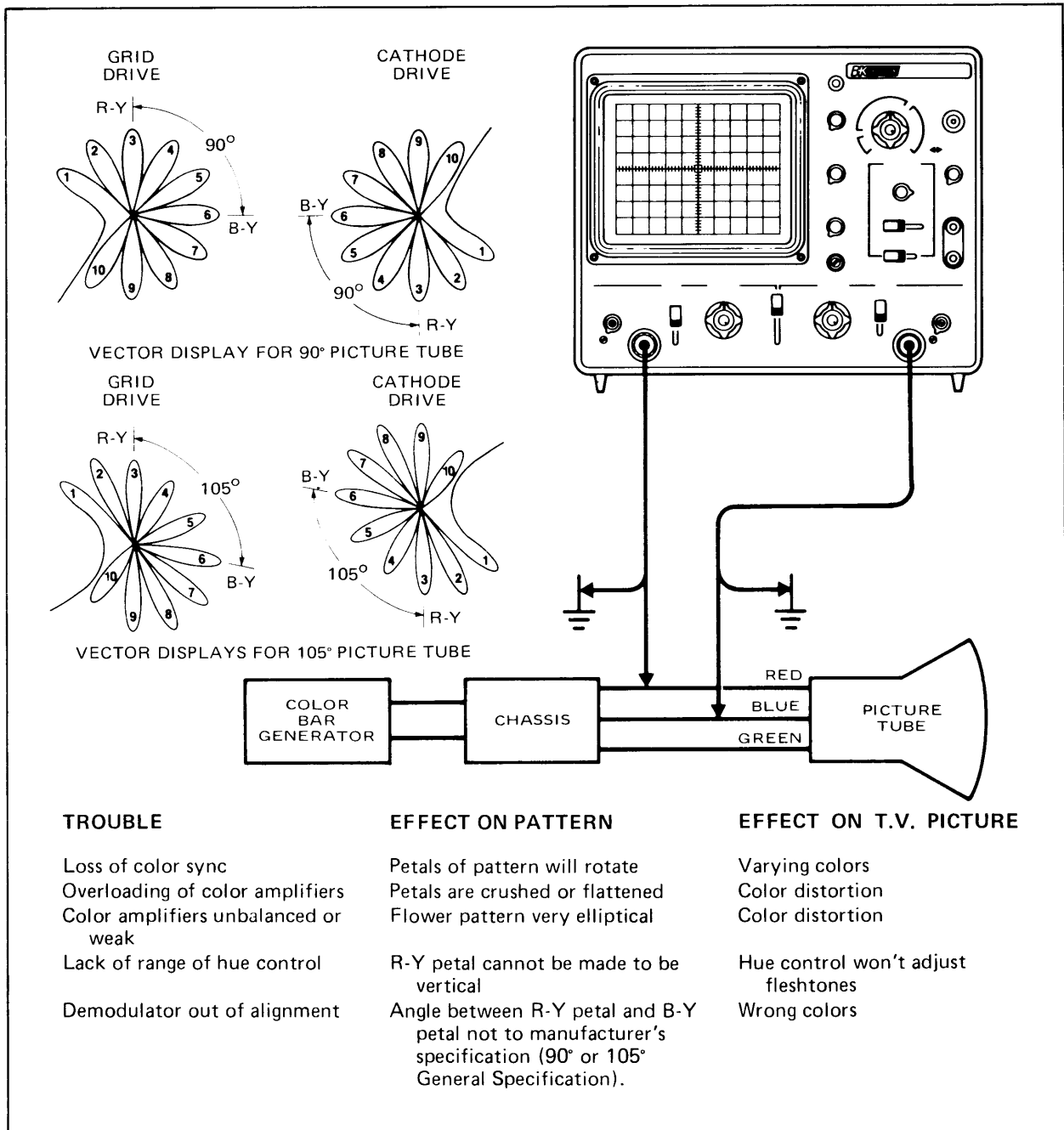

Fig. 31. Vectorscope operation and patterns.

NOTES

TELEVISION ALIGNMENT

INTRODUCTION

Alignment of tuners, the video IF strip, and chroma circuits in television receivers requires a high quality oscilloscope, such as this instrument. The additional pieces of test equipment required are sweep generators for video sweep, IF sweep and RF sweep, marker generators, DC bias supplies and a VTVM. The sweep generator method of alignment displays a bandpass response curve on the screen of the oscilloscope of the type always shown in theory books and in the television set manufacturer's alignment instructions (typical response curves are shown in Fig. 32).

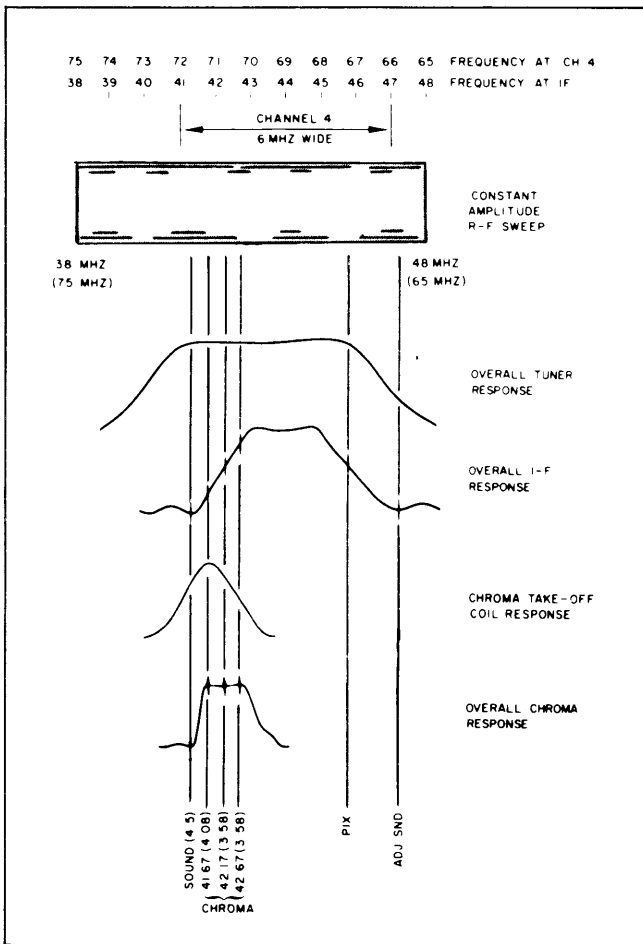

Fig. 32. TV response curves obtained by sweep-frequency technique.

The ideal instruments for television alignment are this oscilloscope and the B & K-Precision Sweep/Marker Generator. The B & K-Precision Sweep/Marker Generator provides all necessary sweep ranges, markers and DC bias voltages, all from one instrument. The simplified operating procedure and calibrated accuracy of the instrument results in precision alignment.

For complete alignment instructions of each particular television set, follow the manufacturer's instructions. However, the following general set-up instructions demonstrates use of the oscilloscope for sweep-frequency alignment.

In this manual, only the proper use of the oscilloscope in television is emphasized. Proper use of the sweep generator and other equipment required for alignment should be provided in the instruction manuals for those instruments.

NOTE

For a comprehensive analysis of television alignment, we recommend the instruction manual for the B & K Model 415 Sweep/Marker Generator. This "handbook of television alignment" includes not only the procedures for using the instrument, but all the how and why answers about television alignment in general. Even if you use other sweep generators, this comprehensive manual provides valuable procedures, insights and tips that will make alignment easier and more professional. The many illustrations and easy-to-understand step-by-step approach qualify it as the "how to align" textbook. Copies are available from your B & K-Precision distributor or the factory.

IMPORTANCE OF SWEEP ALIGNMENT

The most rapid way to determine the overall condition of the tuner, IF and chroma portions of the television receiver is to provide a constant-amplitude signal which sweeps through the entire bandwidth of a given television channel at a controlled, repetitive rate. As this signal is processed through the tuned portions of the receiver, it is shaped by the gain and bandpass properties of the various sections. Because the signal is channeled from one series of tuned circuits to another it is important that each section has the proper characteristics. If the signal is demodulated at certain points and the envelope observed, the gain and bandwidth properties up to that point can be determined.

Fig. 32 shows the sweep signal with basic response curves of the tuner, IF amplifiers and chroma bandpass circuits below it. The bandwidths shown are approximately to scale. These outlines are similar to the curves that would be obtained if the outputs of the various sections of the TV receiver were demodulated and the curve observed on an oscilloscope. Because of the relative bandwidths, the tuner response is least critical.

Some reference frequencies are identified to show the importance of proper alignment. Notice that the chroma frequencies are on the slope of the IF response curve. This area is the most critical because improper IF alignment in this area will affect the amplitude and shape of the chroma response curve and this in turn affects color picture quality.

Notice that the chroma information is located on a constant-amplitude portion of the transmitted television spectrum. Notice that the relative amplitudes of the chroma information are modified by passing through the tuned circuits of the television receiver tuner and IF amplifiers. This is shown by reference to the overall IF response curve. Notice that the signal information at the upper end of the chroma frequency range (4.08 MHz) is reduced in amplitude with respect to the signal level at the lower end of the chroma frequency range (3.08 MHz). To compensate for this frequency-versus-amplitude characteristic of the overall IF response curve, a chroma takeoff coil is used between the IF output and the bandpass amplifier of the chroma portion of the receiver. The chroma takeoff coil is tuned to the upper end of the chroma frequency range, usually 4.08 MHz and provides a response as shown in Fig. 32. This compensates for the amplitude-versus-frequency characteristic of the chroma portion of the overall IF response curve. The result of combining the response of the IF curve and the response of the chroma takeoff coil is to produce a flat overall response in the chroma frequency range (3.08 MHz to 4.08 MHz). The resultant signal is then

applied to the bandpass amplifier which has the response indicated by the overall chroma response curve.

Alignment of the chroma takeoff coil is sometimes specified as a separate step in manufacturer's test procedures. In other procedures, adjustment of the chroma takeoff coil is performed together with the adjustment of the bandpass transformer.

SWEEP ALIGNMENT METHODS

The best method of checking alignment and determining which stages require alignment is to inject an RF sweep frequency signal at the tuner antenna terminals. The AGC bias line must be clamped by application of bias or grounding the AGC line. The outputs of the IF and chroma circuits are then observed on an oscilloscope and compared to the manufacturer's recommended response curve.

The technician can then decide which portions of the receiver require alignment. For example, if the IF response is satisfactory but the chroma response is not, then the problem is between the video detector output of the IF strip and the output of the bandpass amplifier. If the IF response and the chroma response are poor then it is most likely that the IF requires touch-up, particularly if the response is poor on the slope affecting chroma response.

The RF portion of the tuner seldom creates an alignment problem because the passband is so much greater than that of the IF section; however, the mixer output circuit, which is located on the tuner, may require attention. This is part of the tuned matching network between the tuner and the first IF stage. A separate pre-alignment procedure is

given for the link circuits by some manufacturers.

Once the deficient portion of the receiver is determined, an alignment check of that section can be performed. The alignment procedures vary with manufacturers. Some suggest signal combinations at the tuner antenna terminals which can generate IF and video sweep frequencies in the receiver so that overall alignment can be done by selecting the right combination of input signals. One way of doing this is to first connect an RF sweep generator for IF alignment. After this is complete, the picture carrier frequency for the channel being used is selected and this is modulated by a video sweep signal (this is the VSM, or video sweep modulation method). This video sweep modulation is demodulated at the video detector of the TV receiver and applied to the chroma bandpass circuits for the alignment of these stages.

Other manufacturers recommend an IF sweep frequency injected at the mixer grid (or base, if transistorized) for IF alignment. The IF picture carrier frequency (45.75 MHz) is then modulated with a video sweep voltage (VSM again). As before this is detected at the video detector of the TV receiver and the recovered sweep voltage is used for the chroma circuit alignment.

Another method is to first video-sweep align the chroma circuits directly. The IF is then aligned and video sweep modulation of the IF picture frequency (45.75 MHz) is used to check the combined effect on the chroma response of IF alignment and chroma alignment. Usually a touch-up of the chroma circuits is necessary to obtain the desired final overall chroma response.

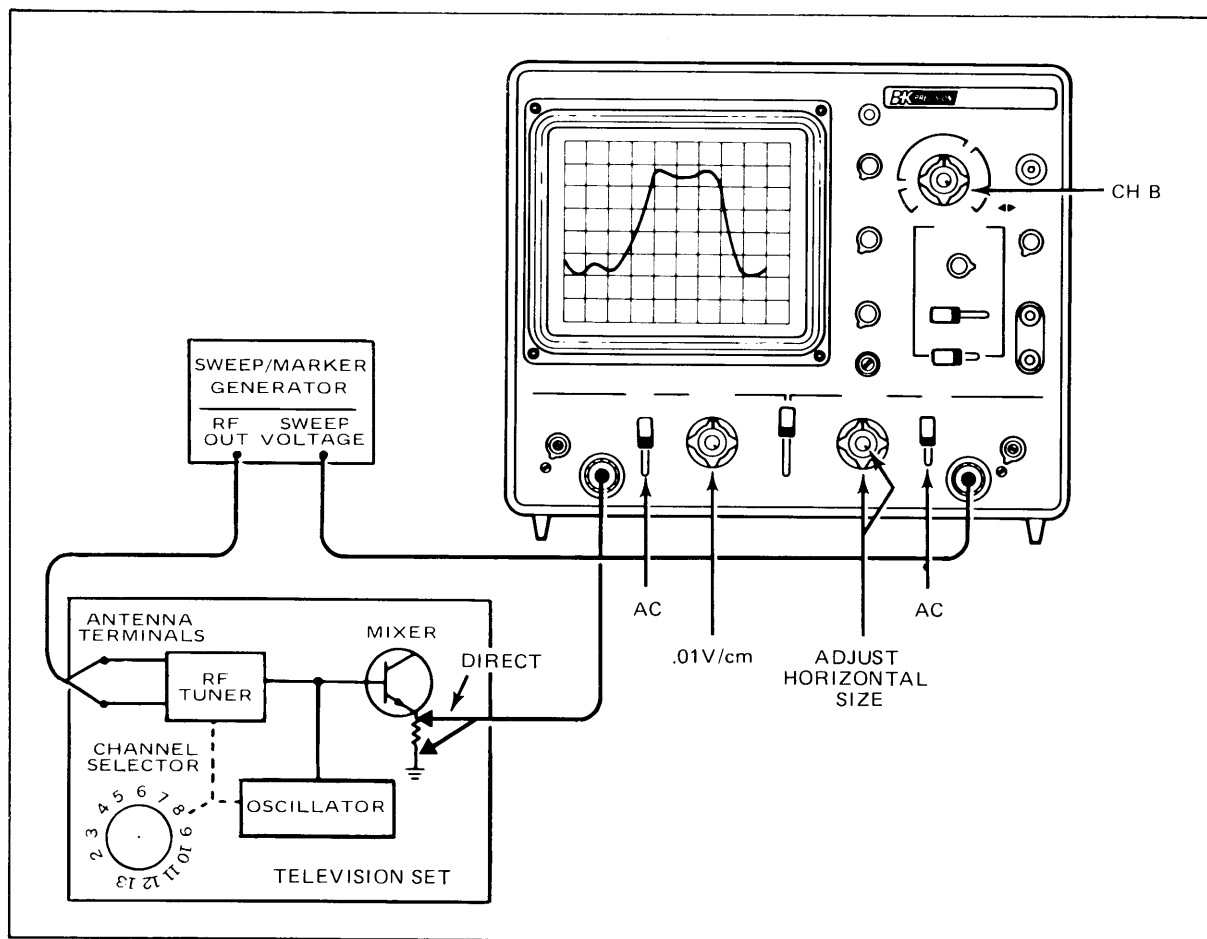

Fig. 33. Typical tuner alignment set-up.

In conjunction with IF alignment, practically all manufacturers recommend pre-tuning IF traps by injecting spot frequencies into the IF (usually at a specified tuner test point). Other procedures outline a prealignment of all tuned circuits in the IF before sweep alignment procedures.

In all cases the manufacturer's method is the best for his particular receiver and the manufacturer's service manual is preferred for alignment. SAMS PHOTOFAC procedures are also reliable and in most cases repeat the manufacturer's procedure. If complete realignment of an apparently deficient receiver does not restore the required response, the technician must then consider that a component failure has occurred and must employ standard troubleshooting procedures.

TUNER ALIGNMENT (Refer to Fig. 33)

1. Connect the output of the sweep generator to the antenna terminals of the television set. Adjust the sweep generator to sweep one of the TV channels.
2. Tune the TV set to the same channel.
3. Connect the ground clip of the oscilloscope probe directly to the tuner shield to minimize hum pickup. Connect the Channel A (Vertical) probe (set to DIRECT) to the tuner test point. The tuner test point is normally the grid of the mixer tube or equivalent, where a demodulated signal is present.
4. Set the vertical controls (CH A VOLTS/CM and VARIABLE) for maximum sensitivity and operate the

sweep generator at low level to avoid overloading the television receiver, which would distort the response curve and provide an erroneous picture of alignment on the oscilloscope screen.

5. The oscilloscope sweep and sweep generator must be in exact synchronization and phase with each other for proper presentation of the response curve. This is easily accomplished for sinusoidal or sawtooth sweep by setting the oscilloscope for external horizontal input (SWEEP TIME/CM to CH B position) and connecting the horizontal sweep voltage from the sweep generator to the Channel B input terminal on the oscilloscope.
6. Select the marker generator frequencies required to measure the upper and lower response of the tuner.
7. The tuner response curve is now displayed on the oscilloscope. See the manufacturer's instructions for the response curve specifications and the necessary adjustments for realignment.

IF ALIGNMENT (Refer to Fig. 34)

1. Connect the output of the sweep generator to the signal injection point of the mixer. Adjust the sweep generator to sweep the IF frequency band. (If the tuner has been properly aligned, RF sweep may be applied at the antenna terminals).
2. Synchronize the oscilloscope sweep with the sweep generator as previously described in the TUNER ALIGNMENT procedure.

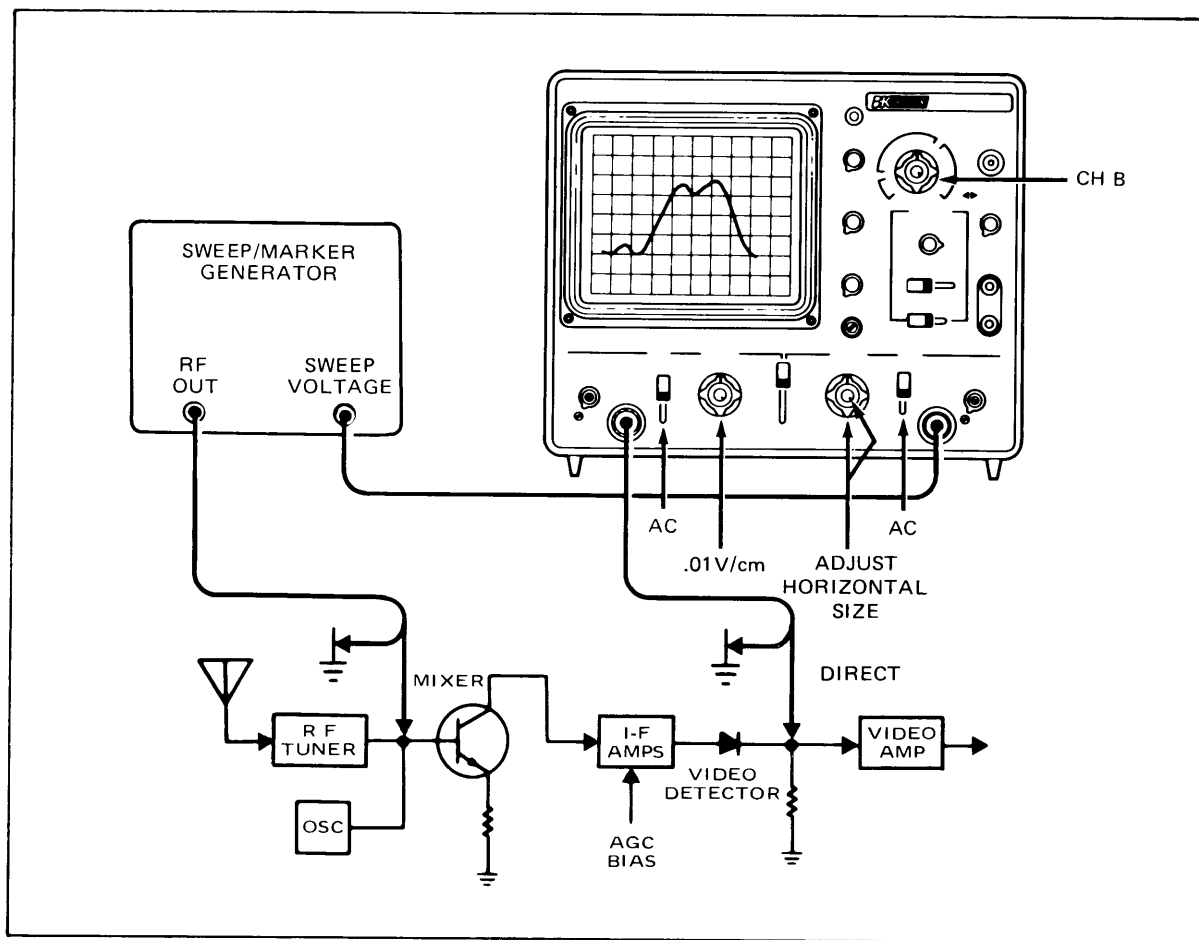

Fig. 34. Typical IF alignment set-up.

3. Connect the ground clip of the oscilloscope vertical probe to the television set chassis.
4. Connect the vertical probe of the oscilloscope to the video detector output.
5. Set the vertical gain controls (CH A VOLTS/CM and VARIABLE) for suitable viewing of the response curve.
6. Keep the sweep generator output level low to prevent overloading. Follow the manufacturer's recommendations on disabling AGC.
7. Select the marker generator frequencies required to check the critical frequencies of interest (see Fig. 35). A sweep and marker generator capable of displaying all the markers simultaneously, such as the B & K-Precision Model 415, is a big advantage.
8. Follow the manufacturer's instructions for evaluating the response curve and making the alignment.

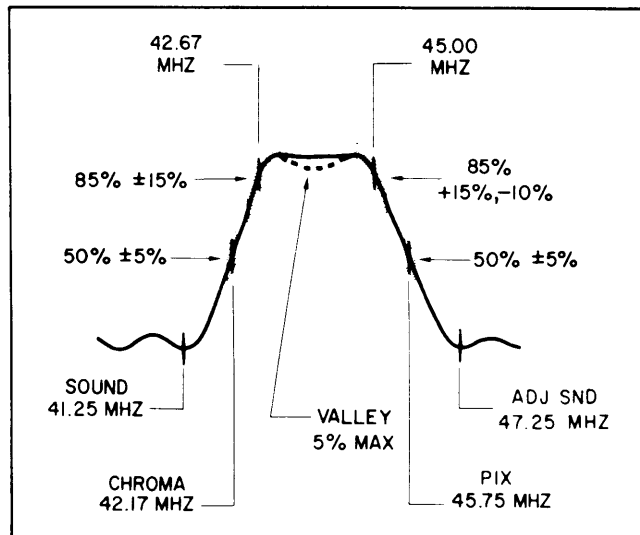

Fig. 35. Typical IF response curve, showing tolerance ranges of response levels.

CHROMA ALIGNMENT (Refer to Fig. 36)

The IF alignment must be satisfactorily completed before starting this chroma alignment procedure. If direct injection of video sweep is used rather than the IF sweep injection specified herein, the response curve is altered drastically. Follow the manufacturer's procedure explicitly for such direct injection of video sweep for chroma alignment.

1. Leave the sweep/marker generator and AGC bias connected as for IF alignment. Set the sweep generator to sweep approximately the 41 to 44 MHz band of frequencies. Use the same IF injection level that was used for IF alignment.
2. Apply the proper DC bias to the color killer to enable the color amplifiers (bandpass amplifiers). Refer to the manufacturer's instructions for the correct bias level.
3. Synchronize the oscilloscope sweep as previously described for tuner alignment.

4. Use a demodulator probe for the vertical input (Channel A) to the oscilloscope. Measure the response curve at the input to the demodulators.
5. Set the vertical gain controls of the oscilloscope (CH A VOLTS/CM and VARIABLE) for a convenient viewing size on the screen.
6. A response curve similar to that shown in Fig. 37 should be seen. Select the marker generator frequencies of interest. Refer to the manufacturer's instructions for bandpass specifications and alignment procedure.

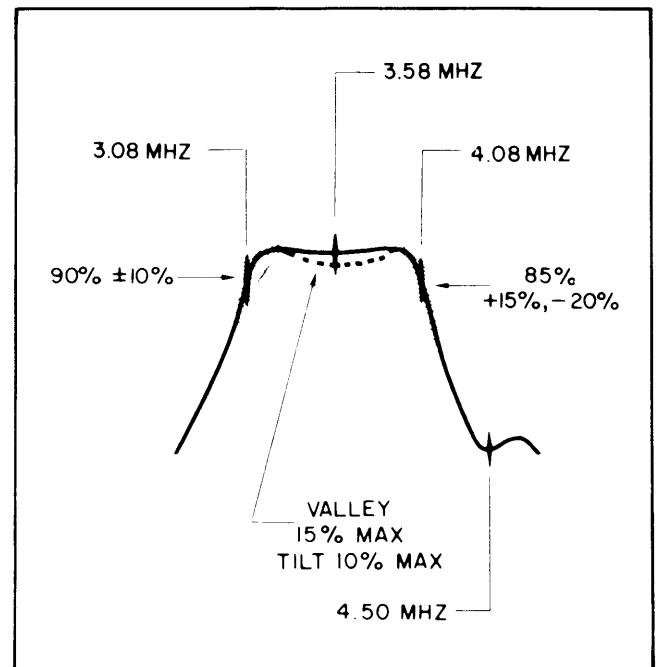

Fig. 37. Typical chroma response curve, showing tolerance ranges of response levels.

NOTES

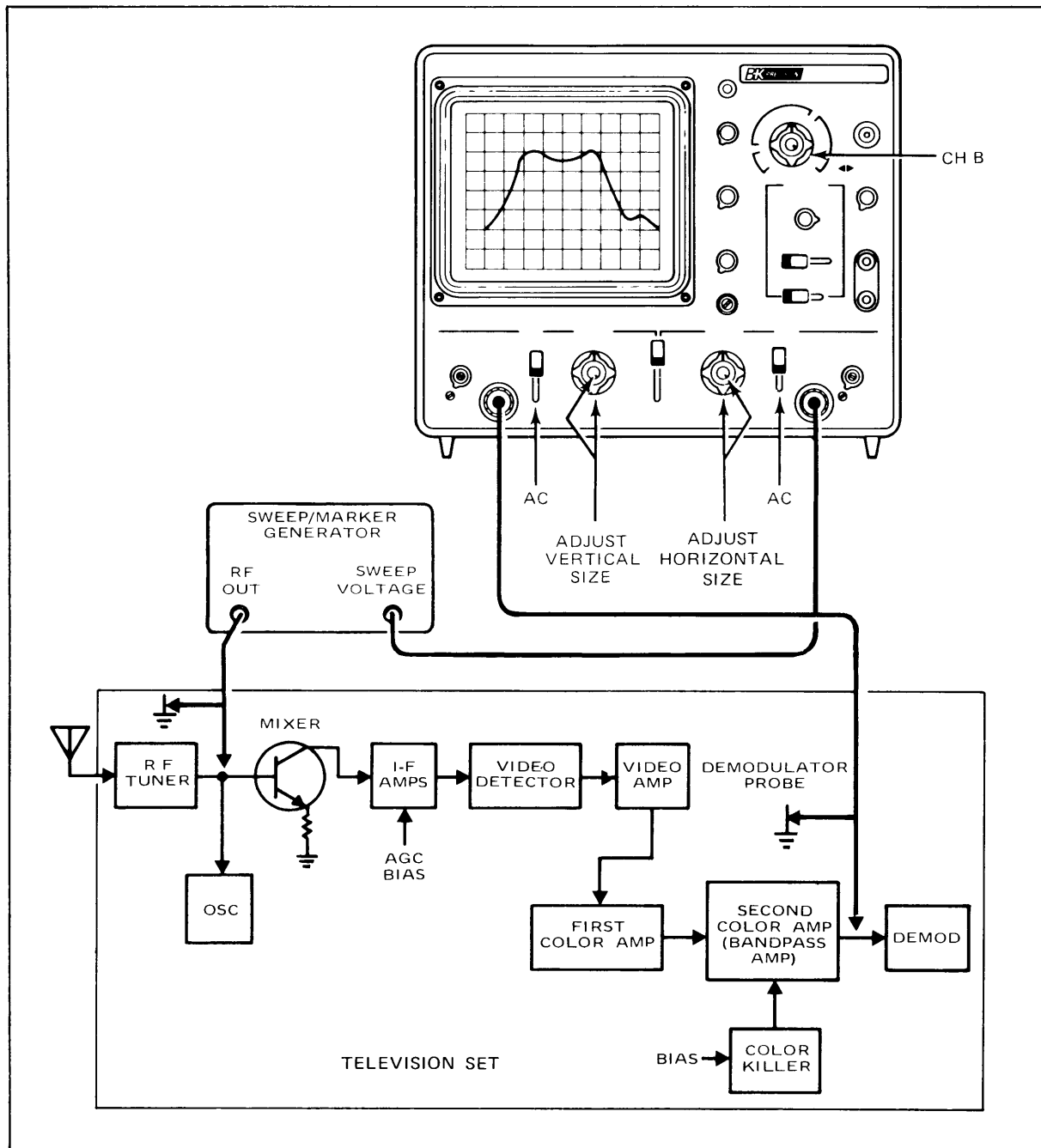

Fig. 36. Typical chroma alignment set-up.

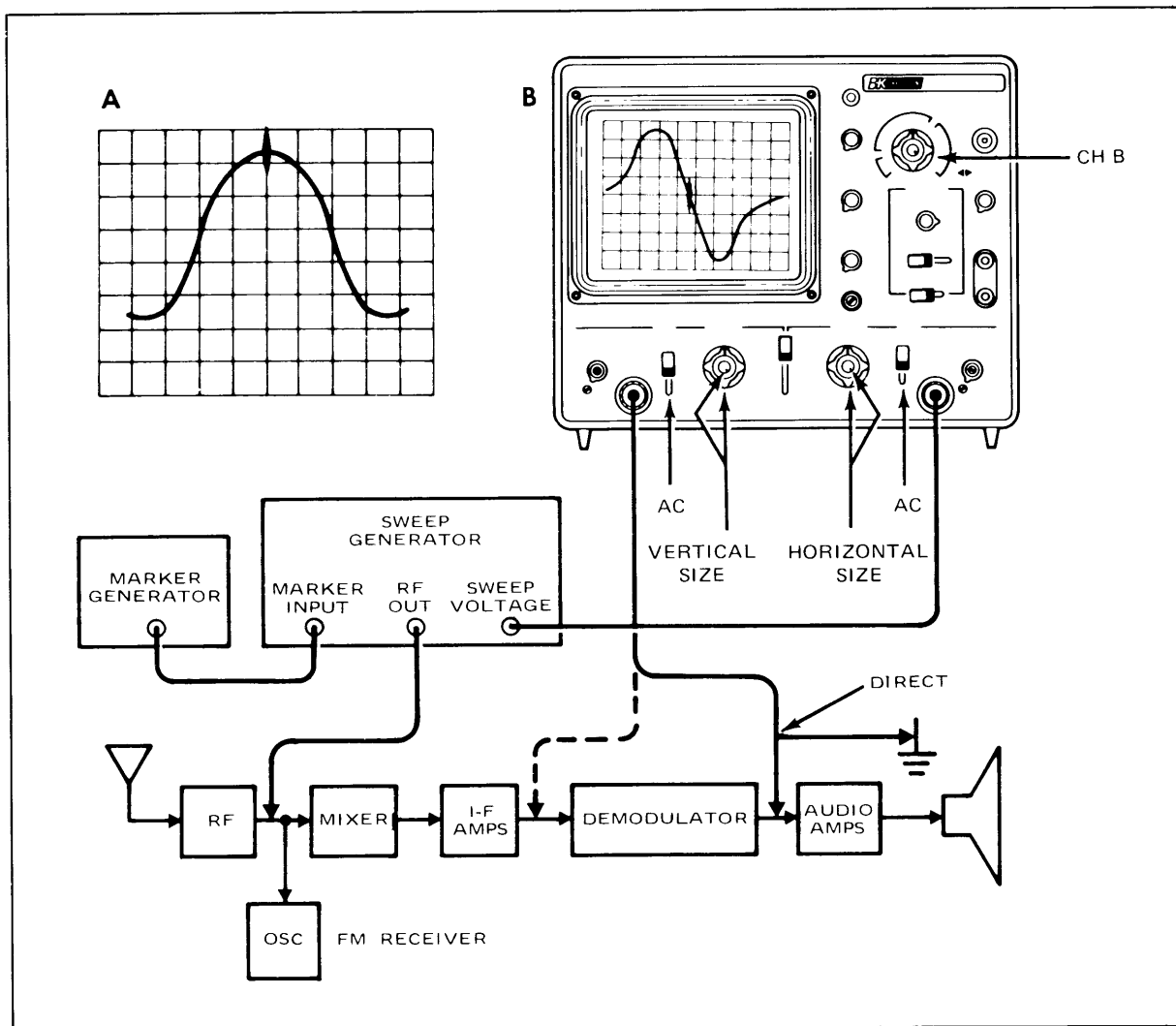

Fig. 38. Typical FM receiver alignment set-up.

FM RECEIVER ALIGNMENT

Refer to Fig. 38

Procedure:

1. Connect a sweep generator to the mixer input of the FM receiver. Set the sweep generator for a 10.7 MHz centered sweep.
2. Connect the sweep voltage output of the sweep generator to the Channel B input jack of the oscilloscope and set the oscilloscope controls for external horizontal sweep (SWEEP TIME/CM to CH B).
3. Connect the vertical input probe to the demodulator input of the FM receiver.
4. Adjust the oscilloscope vertical and horizontal gain controls for display similar to that shown in Fig. 38A.
5. Set the marker generator precisely to 10.7 MHz. The marker "pip" should be in the center of the bandpass.
6. Align the IF amplifiers according to the manufacturer's specifications.
7. Move the probe to the demodulator output. The "S" curve should be displayed, and the 10.7 MHz "pip"

should appear exactly in the center (see Fig. 38B). Adjust the demodulator according to the manufacturer's instructions so the marker moves equal distances from center as the marker frequency is increased and decreased equal amounts from the 10.7 MHz center frequency.

PHASE MEASUREMENT

Phase measurements may be made with an oscilloscope. Typical applications are in circuits designed to produce a specific phase shift, and measurement of phase shift distortion in audio amplifiers or other audio networks. Distortion due to non-linear amplification is also displayed in the oscilloscope waveform.

A sine wave input is applied to the audio circuit being tested. The same sine wave input is applied to the vertical input of the oscilloscope, and the output of the tested circuit is applied to the horizontal input of the oscilloscope. The amount of phase difference between the two signals can be calculated from the resulting waveform.

To make phase measurements, use the following procedure (Refer to Fig. 39).

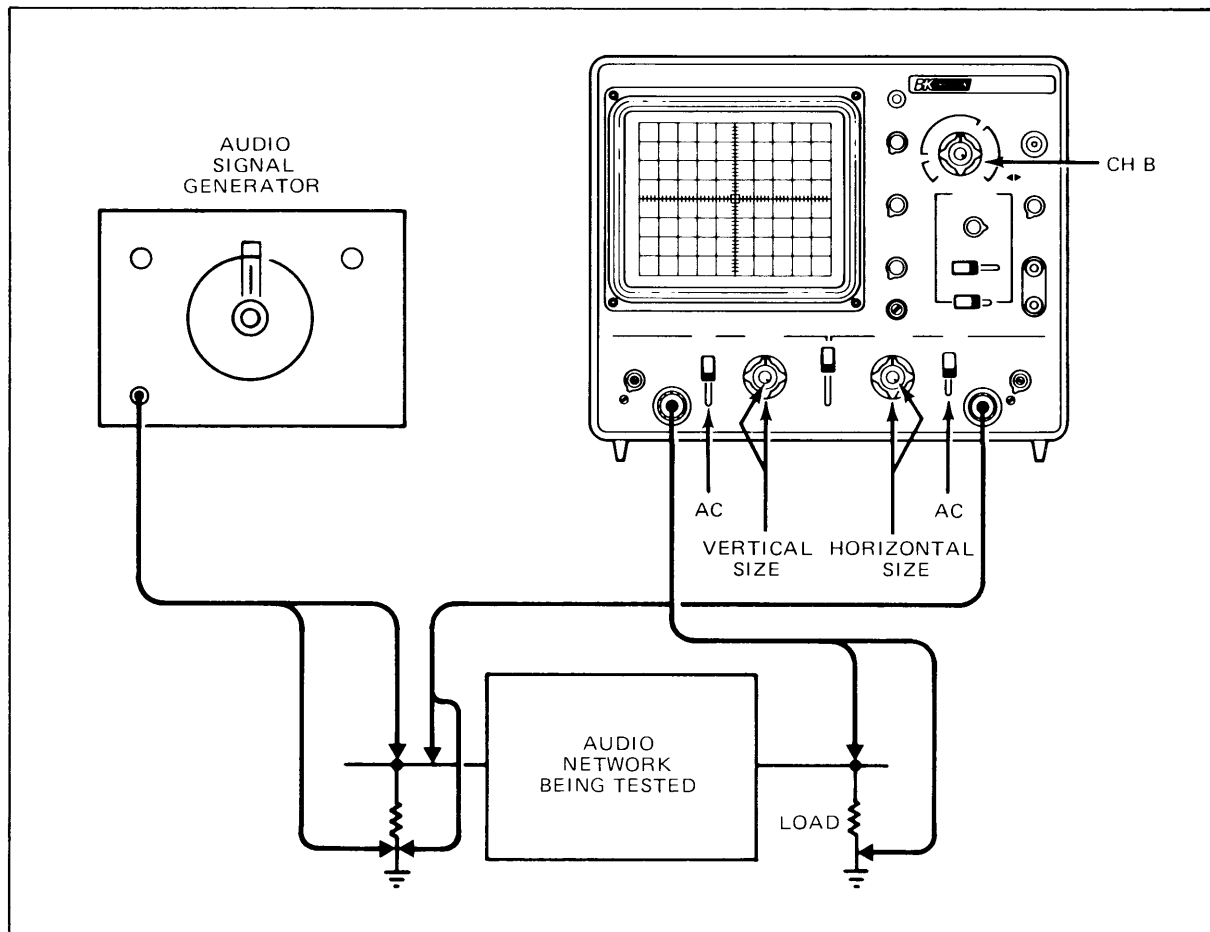

Fig. 39. Typical phase measurement alignment set-up.

1. Using an audio signal generator with a pure sinusoidal signal, apply a sine wave test signal at the desired test frequency to the audio network being tested.
2. Set the signal generator output for the normal operating level of the circuit being tested. If desired, the circuit's output may be observed on the oscilloscope. If the test circuit is overdriven, the sine wave display on the oscilloscope is clipped and the signal level must be reduced.
3. Connect the Channel B probe to the output of the test circuit.
4. Set the SWEEP TIME/CM control to CH B.
5. Connect the Channel A INPUT probe to the input of the test circuit. (The input and output test connections to the vertical and horizontal oscilloscope inputs may be reversed.)
6. Adjust the Channel A and B gain controls for a suitable viewing size.
7. Some typical results are shown in Fig. 40. If the two signals are in phase, the oscilloscope trace is a straight diagonal line. If the vertical and horizontal gain are properly adjusted, this line is at a 45° angle.

A 90° phase shift produces a circular oscilloscope pattern.

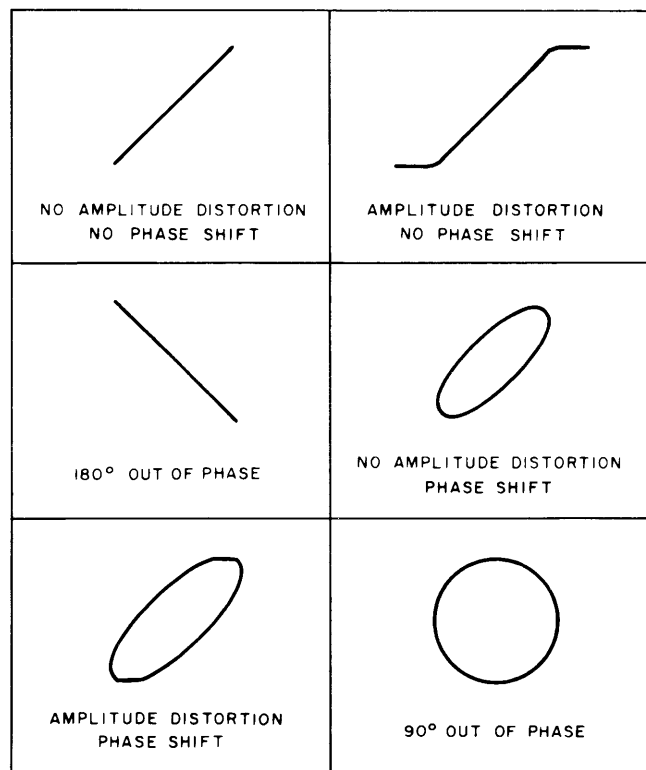

Fig. 40. Typical phase measurement oscilloscope displays.

Phase shift of less (or more) than 90° produces an elliptical oscilloscope pattern. The amount of phase shift can be calculated from the oscilloscope trace as shown in Fig. 41.

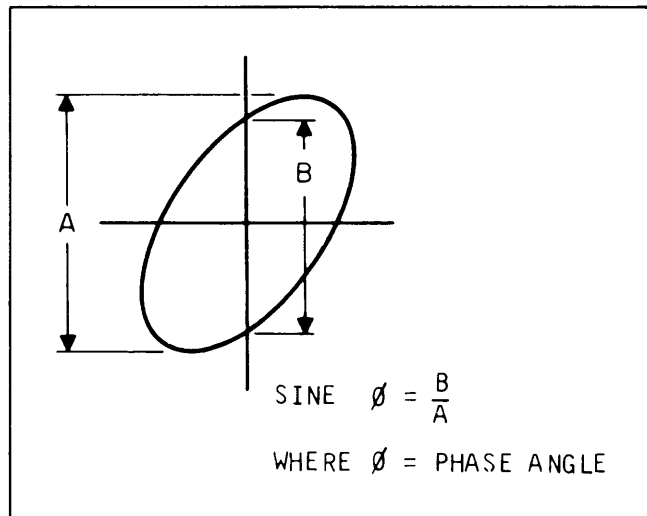

Fig. 41. Phase shift calculation.

FREQUENCY MEASUREMENT

Procedure:

1. Connect the sine wave of known frequency to the CH B INPUT jack of the oscilloscope and set the SWEEP TIME/CM control to CH B. This provides external horizontal input.
2. Connect the vertical input probe (CH A INPUT) to the unknown frequency.
3. Adjust the Channel A and B size controls for a convenient, easy-to-read size of display.
4. The resulting pattern, called a Lissajous pattern, shows the ratio between the two frequencies. See Fig. 42.

SQUARE WAVE TESTING OF AMPLIFIERS

INTRODUCTION

A square wave generator and a low-distortion oscilloscope, such as this instrument, can be used to display various types of distortion present in electronic circuits. A square wave of a given frequency contains a large number of odd harmonics of that frequency. If a 500 Hz square wave is injected into a circuit, frequency components of 1.5 kHz, 2.5 kHz, 3.5 kHz, also are provided. Since vacuum tubes and transistors are non-linear, it is difficult to amplify and reproduce a square wave which is identical to the input signal. Interelectrode capacitances, junction capacitances, stray capacitances as well as limited device and transformer response are a few of the factors which prevent faithful reproduction of a square wave signal. A well-designed amplifier can minimize the distortion caused by these limitations. Poorly designed or defective amplifiers can introduce distortion to the point where their performance is unsatisfactory.

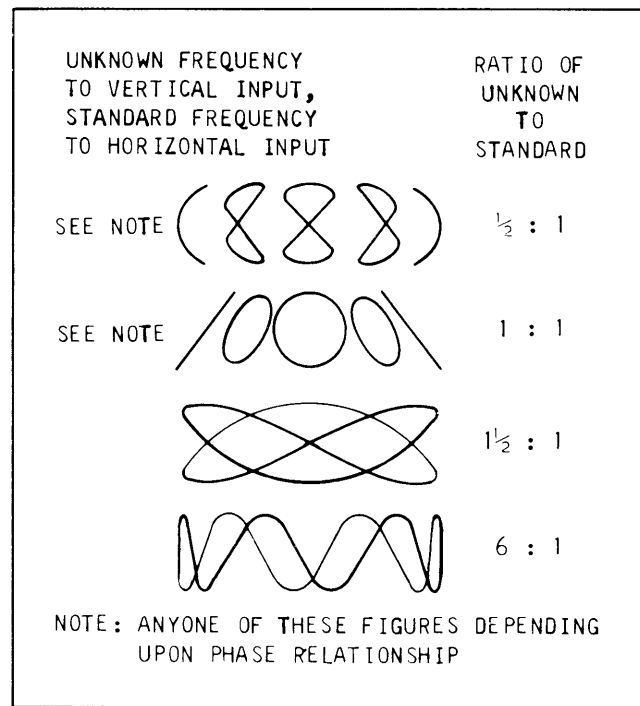

Fig. 42. Lissajous waveforms used for frequency measurement.

As stated before, a square wave contains a large number of odd harmonics. By injecting a 500 Hz sine wave into an amplifier, we can evaluate amplifier response at 500 Hz only, but by injecting a square wave of the same frequency we can determine how the amplifier would respond to input signals from 500 Hz up to the 15th or 21st harmonic.

The need for square wave evaluation becomes apparent if we realize that some audio amplifiers will be required during normal use to pass simultaneously a large number of different frequencies. With a square wave, we have a controlled signal with which we can evaluate the input and output quality of a signal of many frequencies (the harmonics of the square wave) which is what the amplifier sees when amplifying complex waveforms of musical instruments or voices.

The square wave output of the signal generator must be extremely flat so that it does not contribute to any distortion that may be observed when evaluating amplifier response. The oscilloscope vertical input should be set to DC as it will introduce the least distortion, especially at low frequencies. When checking amplifier response, the frequency of the square wave input should be varied from the low end of the amplifier bandpass up toward the upper end of the bandpass; however, because of the harmonic content of the square wave, distortion will occur before the upper end of the amplifier bandpass is reached.

It should be noted that the actual response check of an amplifier should be made using a sine wave signal. This is especially important in limited bandwidth amplifiers (voice amplifiers). The square wave signal provides a quick check of amplifier performance and will give an estimate of overall amplifier quality. The square wave also will reveal some deficiencies not readily apparent when using a sine wave signal. Whether a sine wave or square wave is used for testing the amplifier, it is important that the manufacturer's specifications on the amplifier be known in order to make a better judgment of its performance.

TESTING PROCEDURE (Refer to Fig. 43)

1. Connect the output of the square wave generator to the input of the amplifier being tested.
2. Connect the CH B test probe of the oscilloscope to the output of the amplifier being tested.
3. If the DC component of the circuit being tested is sufficiently low to allow both the AC and DC component to be viewed, use the DC position of the AC-GND-DC switch. However, the AC position may be used without affecting the results except at very low frequencies (below 5 Hz).
4. Adjust the vertical gain controls for a convenient viewing height.
5. Adjust the sweep time controls for one cycle of square wave display on the screen.
6. For a close-up view of a portion of the square wave, use the 5X magnification.

ANALYZING THE WAVEFORMS

The short rise time which occurs at the beginning of the half-cycle is created by the in-phase sum of all the medium and high frequency sine wave components. The same holds true for the rapid drop at the end of the half-cycle from

maximum amplitude to zero amplitude at the 180° or half-cycle point. Therefore, a theoretical reduction in amplitude alone of the high frequency components should produce a rounding of the square corners at all four points of one square wave cycle (See Fig. 44).

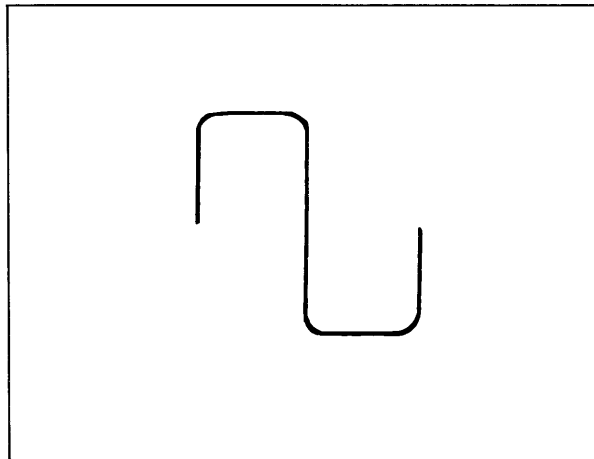

Fig. 44. Square wave response with high frequency loss.

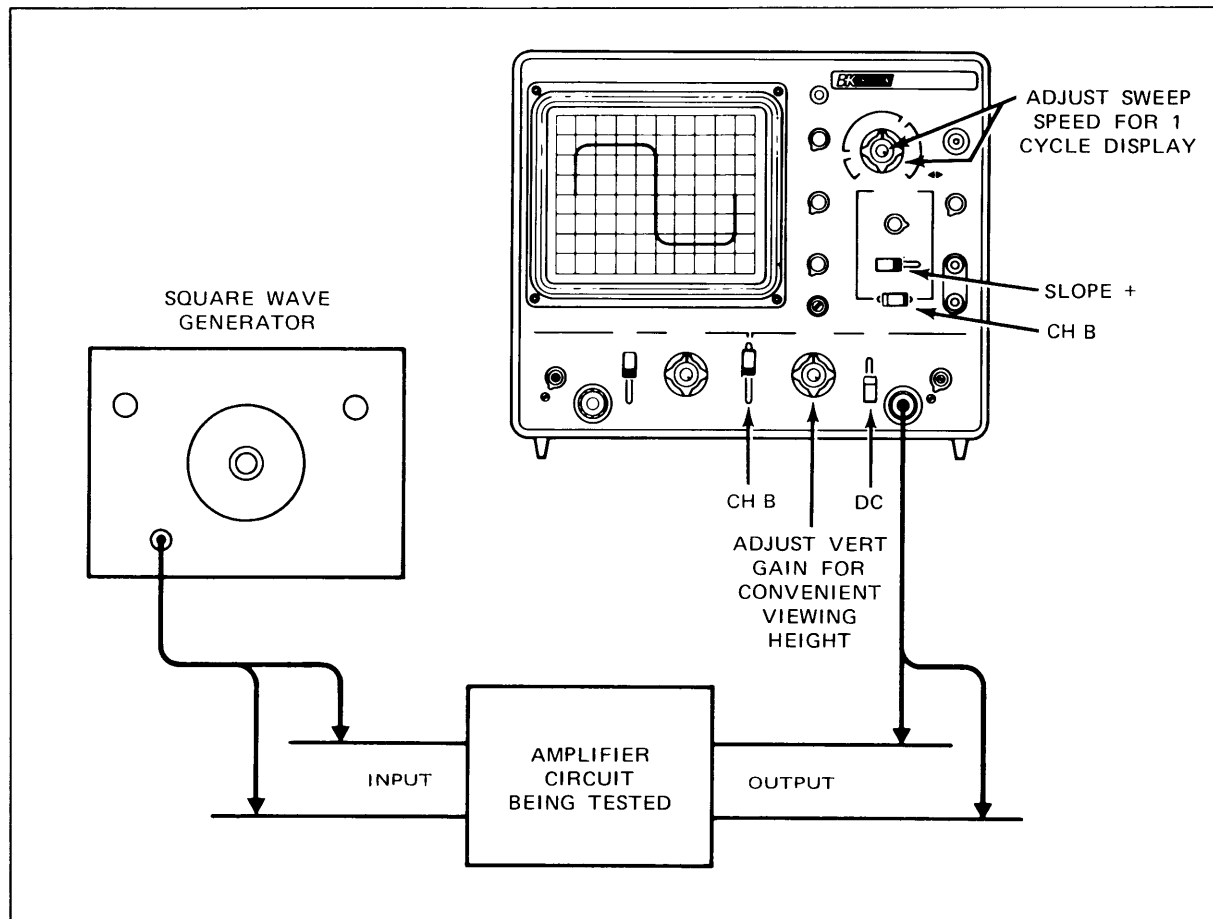

Fig. 43. Equipment set-up for square wave testing of amplifiers.

Distortion can be classified into three distinct categories:

1. The first is frequency distortion and refers to the change from normal amplitude of a component of a complex waveform. In other words, the introduction in an amplifier circuit of resonant networks or selective filters created by combination of reactive components will create peaks or dips in an otherwise flat frequency response curve.
2. The second is non-linear distortion and refers to a change in waveshape produced by application of the waveshape to non-linear components or elements such as vacuum tubes, an iron core transformer, and in an extreme case, a deliberate non-linear circuit such as a clipper network.
3. The third is delay or phase distortion, which is distortion produced by a shift in phase between one or more components of a complex waveform.

In actual practice, a reduction in amplitude of a square wave component (sinusoidal harmonic) is usually caused by a frequency-selective network which includes capacity, inductance or both. The presence of the C or L introduces a difference in phase angle between components, creating phase distortion or delay distortion. Therefore, in square wave testing of practical circuitry, we will usually find that the distorted square wave includes a combination of amplitude and phase distortion clues.

In a typical wide band amplifier, a square wave check accurately reveals many distortion characteristics of the circuit. The response of an amplifier is indicated in Fig. 45, revealing poor low-frequency response along with overcompensated high-frequency boost. A 100 Hz square wave applied to the input of this amplifier will appear as in Fig. 46A. This figure indicates satisfactory medium frequency response (approximately 1 kHz to 2 kHz) but shows poor low frequency response. Next, a 1000 Hz square wave applied to the input of this same amplifier will appear as in Fig. 46B. This figure displays good frequency response in the region of 1000 to 4000 Hz but clearly reveals the overcompensation at the higher 10 kHz region by the sharp rise at the top of the leading edge of the square wave.

As a rule of thumb, it can be safely said that a square wave can be used to reveal response and phase relationships up to the 15th or 20th odd harmonic or up to approximately 40 times the fundamental of the square wave. Using this rule of thumb, it is seen that wide-band circuitry will require at least a two-frequency check to properly analyze the complete spectrum. In the case illustrated by Fig. 45, a 100 Hz square wave will encompass components up to about 4000 Hz. To analyze above 4000 Hz and beyond 10,000 Hz, a 1000 Hz square wave should be satisfactory.

Now, the region between 100 Hz and 4000 Hz in Fig. 45 shows a rise from poor low-frequency response to a flattening out from beyond 1000 and 4000 Hz. Therefore, we can expect that the higher frequency components in the 100 Hz square wave will be relatively normal in amplitude and phase but that the lower frequency components in this same square wave will be strongly modified by the poor low-frequency response of this amplifier. See Fig. 46A.

If the combination of elements in this amplifier were such as to only depress the low frequency components in the square wave, a curve similar to Fig. 47 would be obtained. However, reduction in amplitude to a component, as already noted, is usually caused by a reactive element, causing, in turn, a phase shift of the component,

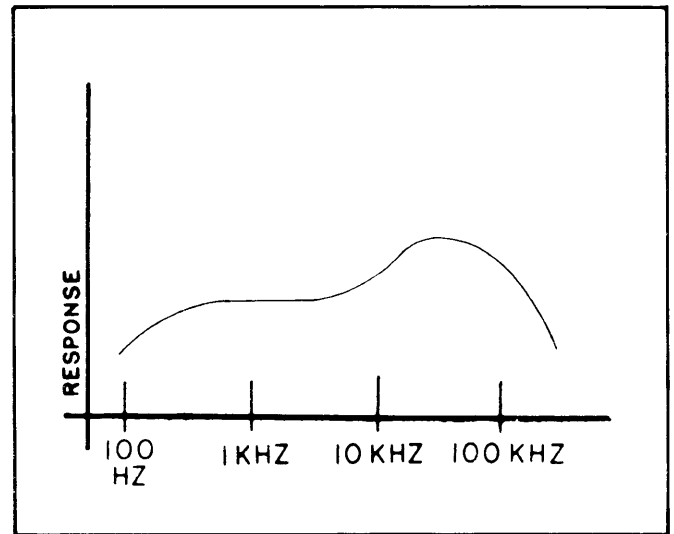

Fig. 45. Response curve of amplifier with poor low and high ends.

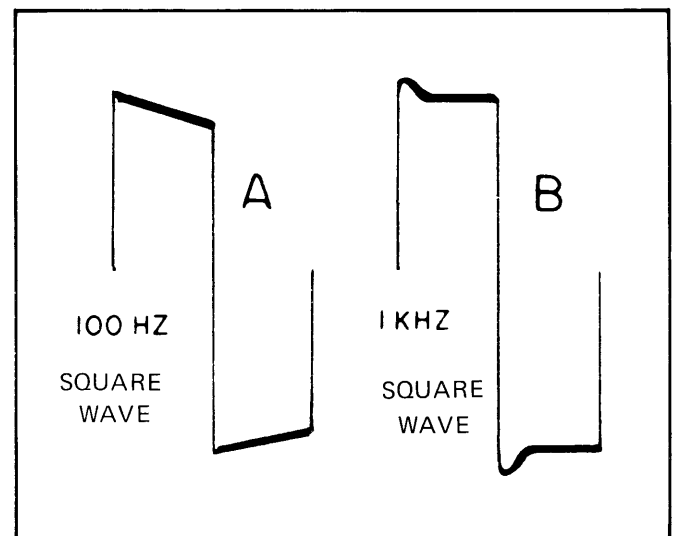

Fig. 46. Resultant 100 Hz and 1 kHz square waves from amplifier in Fig. 45.

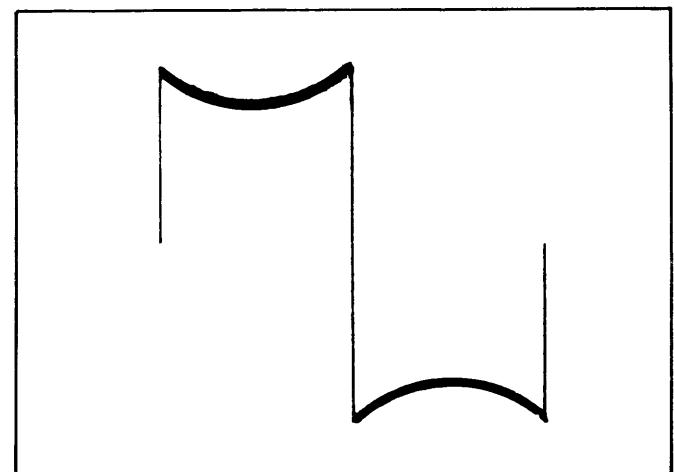

Fig. 47. Reduction of square wave fundamental frequency component in a tuned circuit.

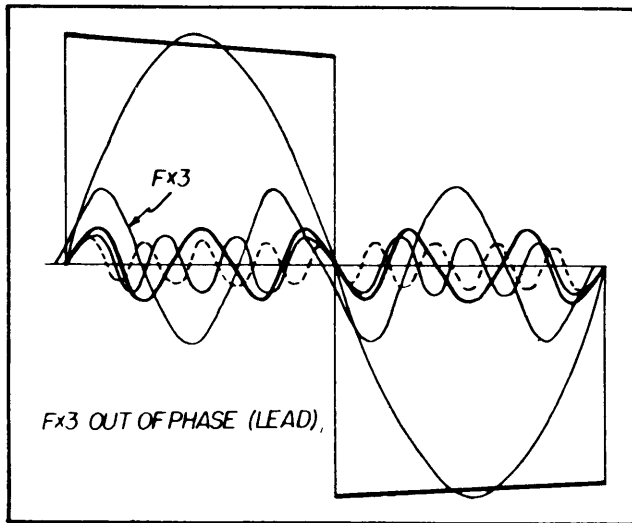

Fig. 48. Square wave tilt resulting from 3rd harmonic phase shift.

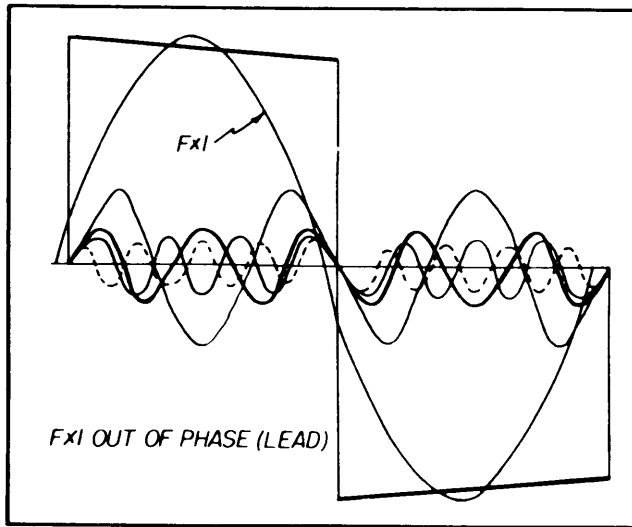

Fig. 49. Tilt resulting from phase shift of fundamental frequency in a *leading* direction.

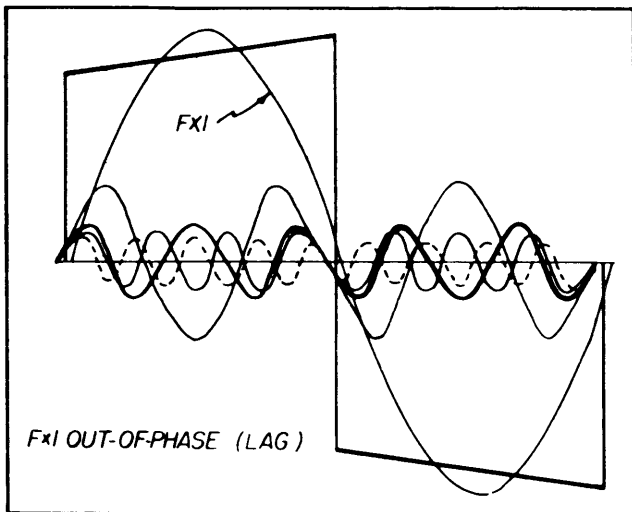

Fig. 50. Tilt resulting from a phase shift of fundamental frequency in a *lagging* direction.

producing the strong tilt of Fig. 46A. Fig. 48 reveals a graphical development of a similarly tilted square wave. The tilt is seen to be caused by the strong influence of the phase-shifted 3rd harmonic. It also becomes evident that very slight shifts in phase are quickly shown up by tilt in the square wave.

Fig. 49 indicates the tilt in square wave shape produced by a 10° phase shift of a low frequency element in a leading direction. Fig. 50 indicates a 10° phase shift in a low frequency component in a lagging direction. The tilts are opposite in the two cases because of the difference in polarity of the phase angle in the two cases as can be checked through algebraic addition of components.

Fig. 51 indicates low frequency components which have been reduced in amplitude and shifted in phase. It will be noted that these examples of low frequency distortion are characterized by change in shape of the flat top portion of the square wave.

Fig. 46B, previously discussed, revealed high-frequency overshoot produced by rising amplifier response at the higher frequencies. It should again be noted that this overshoot makes itself evident at the top of the leading edge of the square wave. This characteristic relationship is explained by remembering that in a normal well-shaped square wave, the sharp rise of the leading edge is created by the summation of a practically infinite number of harmonic components. If an abnormal rise in amplifier response occurs at high frequencies, the high frequency components in the square wave will be amplified disproportionately greater than other components creating a higher algebraic sum along the leading edge.

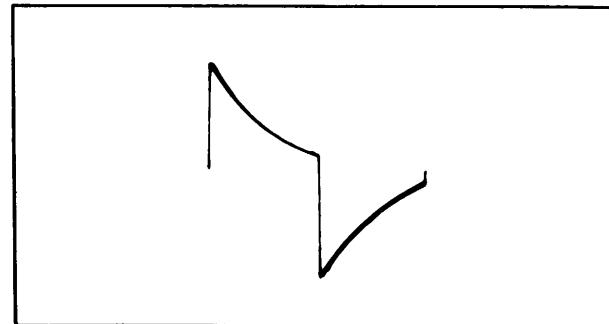

Fig. 51. Low frequency component loss and phase shift.

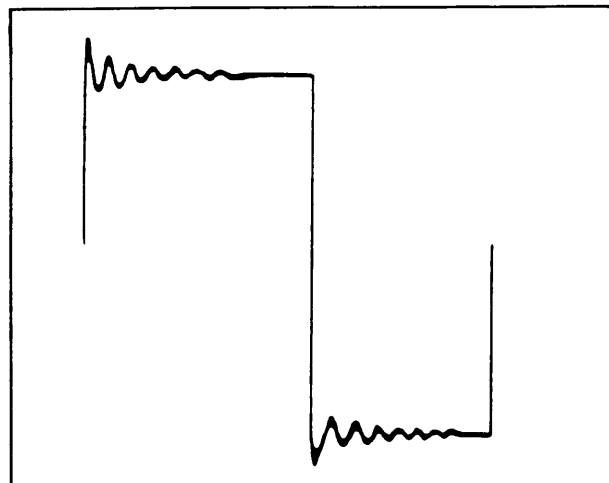

Fig. 52. Effect of high-frequency boost and *poor* damping.

Fig. 52 indicates high frequency boost in an amplifier accompanied by a lightly damped "shock" transient. The sinusoidal type of diminishing oscillation along the top of the square wave indicates a transient oscillation in a relatively high "Q" network in the amplifier circuit. In this case, the sudden transition in the square wave potential from a sharply rising, relatively high frequency voltage, to a level value of low frequency voltage, supplies the energy for oscillation in the resonant network. If this network in the amplifier is reasonably heavily damped, then a single cycle transient oscillation may be produced as indicated in Fig. 53.

Fig. 54 summarizes the preceding explanations and serves as a handy reference.

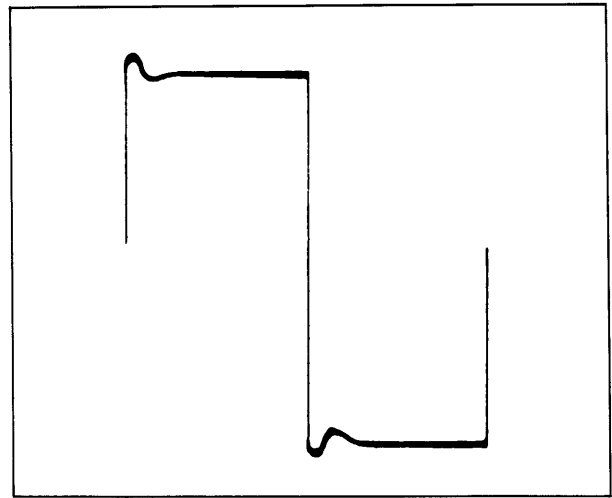

Fig. 53. Effect of high-frequency boost and good damping.

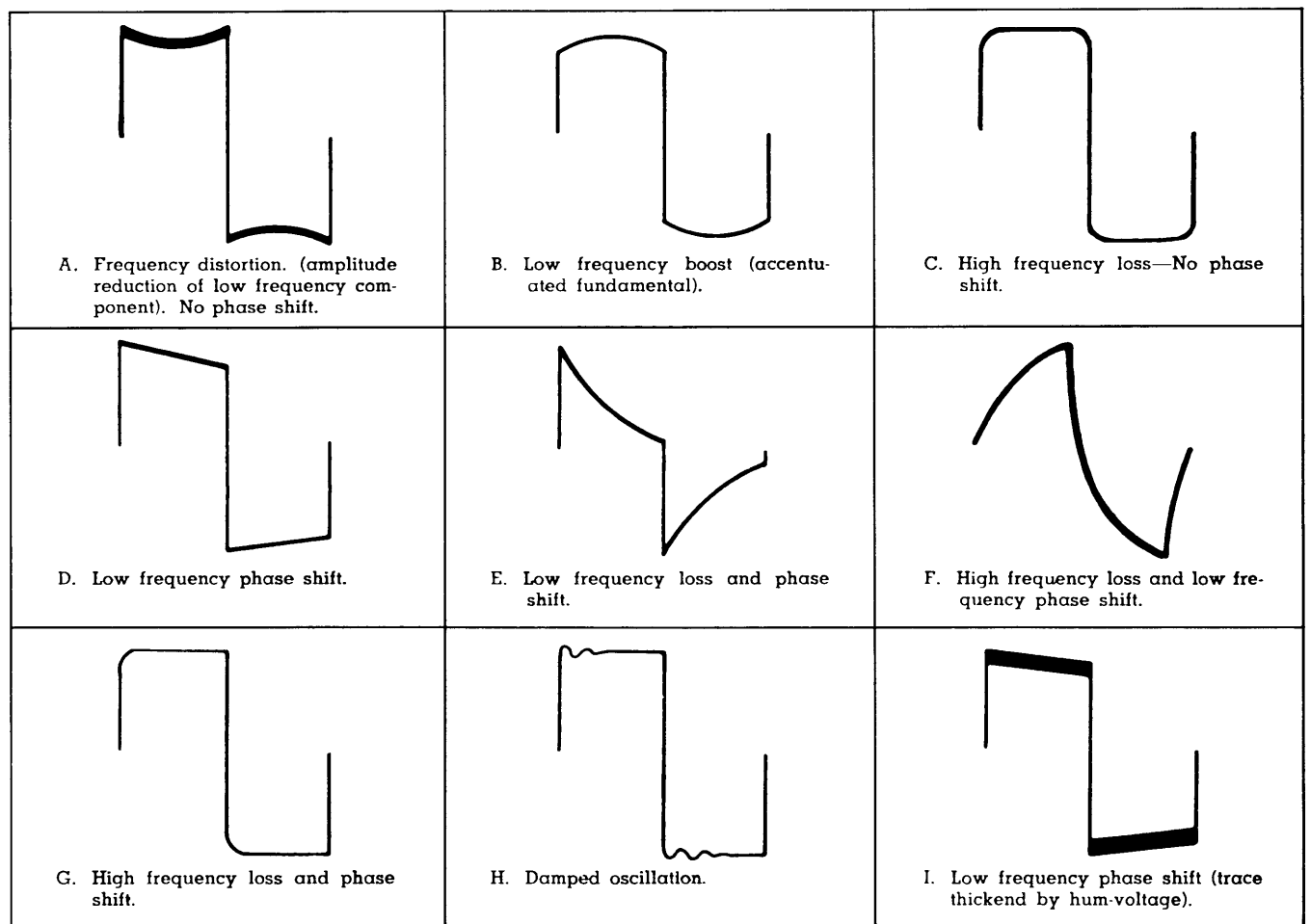

Fig. 54. Summary of waveform analysis for square wave testing of amplifiers.

CIRCUIT DESCRIPTION

The block diagram, Fig. 55, outlines the circuit breakdown of the oscilloscope. Circuit details are obtained by reference to the schematic diagram.

GENERAL

Basically, the oscilloscope consists of two identical vertical preamplifiers, each having its own input attenuator network. The outputs of the vertical preamplifiers can be switched, as desired, into the main vertical amplifier. The type of switching of the CH A and CH B preamplifiers is determined by the position of the MODE switch and MODE of OPERATION LOGIC. The main vertical amplifier feeds the VERTICAL OUTPUT AMPLIFIER, which drives the vertical deflection plates of the CRT.

Horizontal deflection is provided by the horizontal amplifier. Drive to the horizontal amplifier is furnished by calibrated sweep speed circuits or by the signal from the CH B preamplifier when X-Y operation is selected.

All supply voltages are fully regulated and a DC-to-DC converter provides a regulated 2kV accelerating potential to the CRT.

VERTICAL PREAMPLIFIERS

Channel A and Channel B preamplifiers contain identical circuitry and circuit operation is the same for both.

The vertical attenuator has two sections. The first section of the attenuator provides ratios of 1:1, 10:1, 100:1, 1000:1. The second section provides ratios of 2:1 and 5:1. The combined effect of the two sections is to provide the vertical attenuator ratios in a 1-2-5 sequence.

The vertical preamplifier consists of FET input transistors Q102 and Q103 and transistors Q104 thru Q109. FET's Q102 and Q103 form a balanced differential amplifier pair with output signals of opposite polarity. VR101 is the front panel DC balance control and VR112 an internal balance control. The output of Q102 and Q103 is applied to emitter followers Q104 and Q105 which lower the output impedance to drive conventional amplifier stage Q106 and Q107. VR105 and VR106 are balance pots for the 1/2 and 1/5 attenuator positions. The VARIABLE control adjusts the gain of Q106 and Q107 while VR101 provides a DC component to move the trace vertically across the screen. Amplifier gain is adjusted by VR107 in the emitter circuit of Q108 and Q109 to provide the correct deflection factor for accurate voltage measurements.

The trigger amplifier Q119 and Q120 amplifies the signal at the emitter of Q108 and Q109 and provides a portion of the signal to the trigger circuits.

The only difference between CH A and CH B preamplifiers is that the MODE switch reverses the polarity of the CH B signal when in the A-B position.

MODE LOGIC

The mode of operation (CH A, CH B, A & B, A + B, A - B) is controlled by IC101 and IC102 and diodes D101 - D108 in each of the channel preamplifiers.

When CH A is selected, the output of IC102 Pin 3 is low, which reverse-biases D102 and D103 and forward-biases D101 and D104, allowing the CH A signal into the main vertical amplifier. At the same time IC102 Pin 11 output is

high which forward-biases D106 and D107 and reverse-biases D105 and D108 prohibiting CH B signal from the main amplifier. For CH B, the reverse is true. When A & B is selected, both channels are alternately switched by IC101 at a rate equal to the chopping oscillator frequency (200kHz). For A + B and A - B, both channels are simultaneously applied to the main amplifier. When X-Y operation is selected, CH A is turned on and CH B is switched to the horizontal amplifier.

VERTICAL AMPLIFIER

The selected signal from the preamplifiers is then applied to the vertical amplifier which consists of Q123, Q124 and IC103. The signal level is increased to drive the output amplifier.

The output amplifier consists of transistors Q301 thru Q306 where the signal is amplified to the levels required to drive the vertical deflection plates of the CRT.

TRIGGER CIRCUIT

The trigger source, either CH A or CH B, is selected by SW201. Selecting CH A as the source enables trigger amplifier Q119 and Q120 and CH B enables trigger amplifier Q121 and Q122. The trigger amplifier selected is fed thru transistor switch Q219. Q219 is on in all positions of the SWEEP TIME/CM switch except CH B.

SYNC AMPLIFIER AND INVERTER

Transistors Q201, Q202, Q203, and Q204 are connected as a differential amplifier. The trigger signal is applied to emitter follower Q201 and routed to the base of Q202 or Q203 depending upon the position of the SYNC switch, SW202, + or - respectively. Emitter follower Q204 adds a DC level to the trigger signal depending upon the position of the TRIGGER LEVEL control.

When TV+ or TV- is selected, the output of Q203 is routed to the SYNC SEPARATOR circuit consisting of Q205 and Q206. Q205 is biased near cutoff. Q205 is held cutoff by the negative voltage developed across Q205 corresponding to an average value of the input signal. Positive-going pulses drive Q205 out of cutoff. The output of Q205 corresponds to the sync tips of the composite video signal.

When in TVV positions of time base switch (.1mS to .5 SEC), capacitor C207 is switched in by Q206 to filter out the horizontal sync pulses.

The trigger signal passes thru emitter follower Q207 and the SCHMITT TRIGGER circuit consisting of two gates of IC201. The output pulses from IC201 PIN 8 clock the SWEEP CONTROL flip-flop IC202. On the negative edge of the clock waveform, the Q output goes low, turning off Q213 to initiate to sweep.

Transistors Q216 and Q217 and the timing capacitors and resistors selected by the SWEEP TIME/CM switch form a MILLER INTEGRATING circuit to provide a linear ramp voltage. The sweep ramp from the collector of Q217 is fed to the RS flip-flop consisting of two gates from IC201 thru transistor Q211 and Q212.

As soon as the Q output of IC202 goes low, the reset of IC202 is held low by Q211 to exclude any new clock pulses until the sweep ramp is terminated. Transistor Q212 turns on and sets pin 13 of IC202 LOW which turns Q213 on and terminates the sweep.

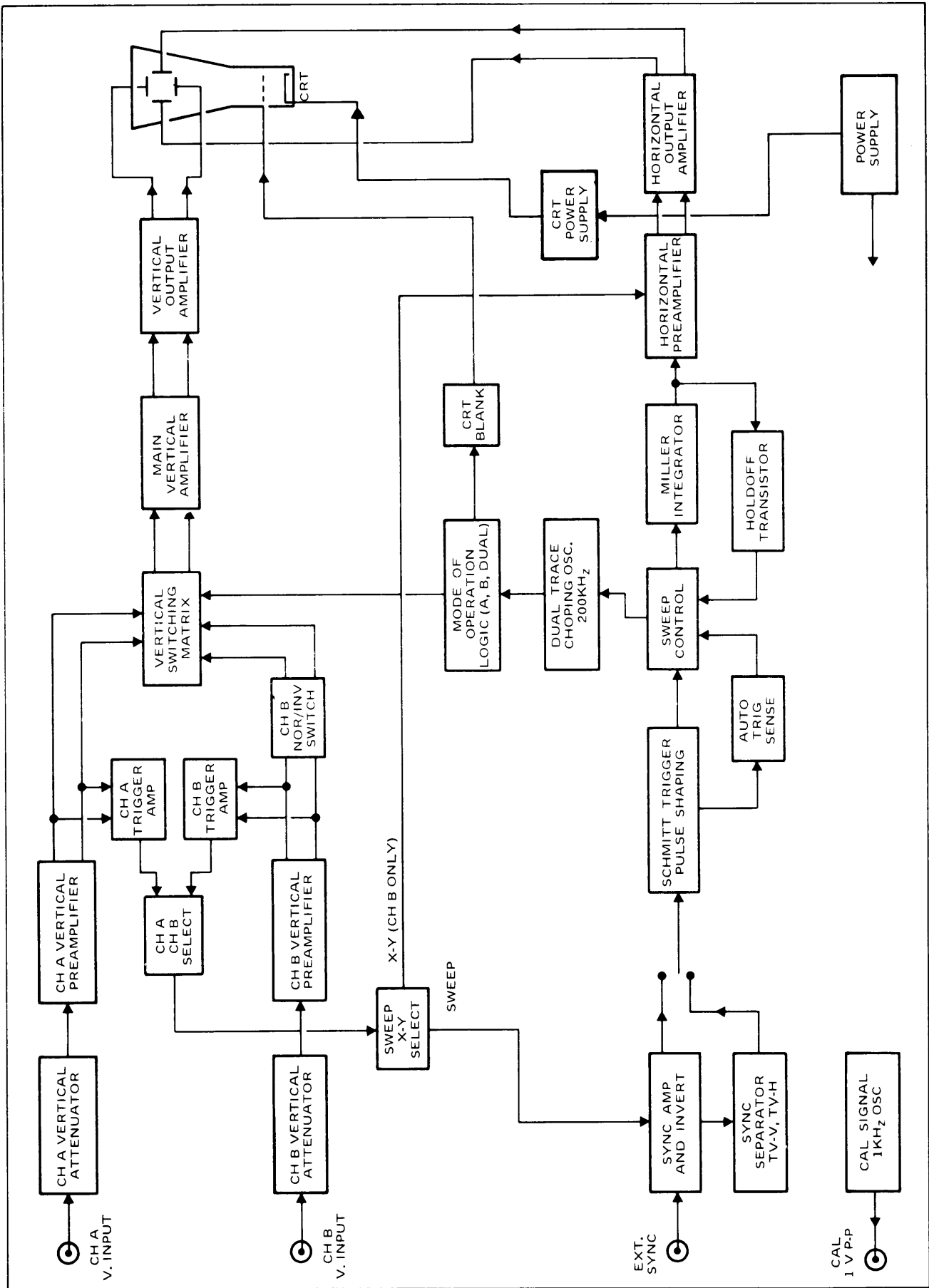

Fig. 55. Block diagram, Model 1472 Dual-Trace Oscilloscope.

Transistors Q208, Q209, and Q210 form the AUTO TRIGGER SENSE switch. When the TRIG LEVEL control is adjusted so that the slope is not triggered, transistor Q8 and Q9 produce pulses which keep Q210 ON. The on condition is applied to the RESET of IC202. A low on the reset of IC202 allows a sweep to recirculate at a rate determined by the resistor and capacitor selected by the TIME/CM switch.

The sweep ramp from the collector of Q217 is applied to the input of the horizontal amplifier consisting of Q218, Q220, Q221 – Q225.

When in the CH B position of SWEEP TIME/CM switch, mode, transistor Q219 is turned off thru IC203 and the CH B signal is applied to Q220 and to the horizontal amplifier. The output of transistors Q224 and Q225 is applied to the horizontal deflection plates of the CRT.

CALIBRATION ADJUSTMENTS

The calibration adjustments outlined here are those which can be performed with a minimum of specialized test equipment. Additional internal adjustments of frequency compensation and horizontal sweep linearity should not be attempted without complete service information and specified test equipment. Requests for complete service information for this oscilloscope should be addressed to:

Service Department

B & K-Precision Product Group
DYNASCAN CORPORATION
2815 West Irving Park Road
Chicago, Illinois 60618

Internal adjustments outlined in the calibration procedure can be located by reference to Fig. 56 and 57.

HOUSING REMOVAL

1. Remove 6 screws, 2 on left side, 2 on right side, and 2 on top.

230 VAC OPERATION

1. Remove housing from scope.
2. Remove voltage selector plug (see Fig. 58).
3. Rotate plug 180° and re-insert plug.
4. Replace 0.7A fuse with 0.3A fuse.
5. Replace housing.

GRATICULE REMOVAL

1. Grasp bezel with both hands at top and bottom. Pull bezel uniformly forward to unlock mounting legs from front panel. Caution should be used to keep bezel parallel to front panel when removing, to avoid breakage of mounting legs.
2. Lift off graticule from bezel.
3. Reinsert graticule on bezel and snap bezel into front panel mounting holes.

CH A AND CH B DC BALANCE

1. Adjust controls to obtain a horizontal trace (CH A or CH B).
2. Adjust CH A or CH B POSITION control to center the trace vertically on the CRT.
3. Rotate the VARIABLE control from maximum CCW to maximum CW while observing the trace.
4. If the trace moves vertically more than 5mm while performing STEP 3, adjust the CH A or CH B DC BAL (front panel screwdriver adjustment) so that the vertical movement of the trace does not exceed 5mm while performing STEP 3.

1/2 & 1/5 ATTENUATOR BALANCE

1. Position trace to vertical center of screen CH A or CH B, with V ATTENUATOR in .01 V/CM and input at GND.
2. Switch to .02 V/CM and adjust VR105 (CH A) or VR108 (CH B) until trace is at vertical center.
3. Switch to .05 V/CM and adjust VR106 (CH A) or VR109 (CH B) until trace is at vertical center.

VERTICAL GAIN ADJUSTMENT

The following adjustments should be attempted *only* if a square wave generator with 1% or better amplitude accuracy is available.

Procedure:

1. Set CH A and CH B VOLTS/CM switches to .01V/CM and set CH A and CH B VARIABLE controls to CAL (fully clockwise).
2. Apply 1 kHz square wave of 50 mV peak-to-peak into CH A input connector. Set mode switch to CH A.
3. Adjust VR107 for exactly 5 CM of deflection on CRT.
4. Repeat steps 2 and 3 for CH B and adjust VR110 for 5 CM deflection.

HORIZONTAL POSITION ADJUSTMENT

1. Set ◀▶ POSITION control mechanical center.
2. Set SWEEP TIME/CM switch to EXT.
3. Adjust VR206 so that the spot on the scope is horizontally centered on CRT.
4. Turn the ◀▶ POSITION control full CW and CCW. The amount of deflection in both directions should be a minimum of 4 CM.

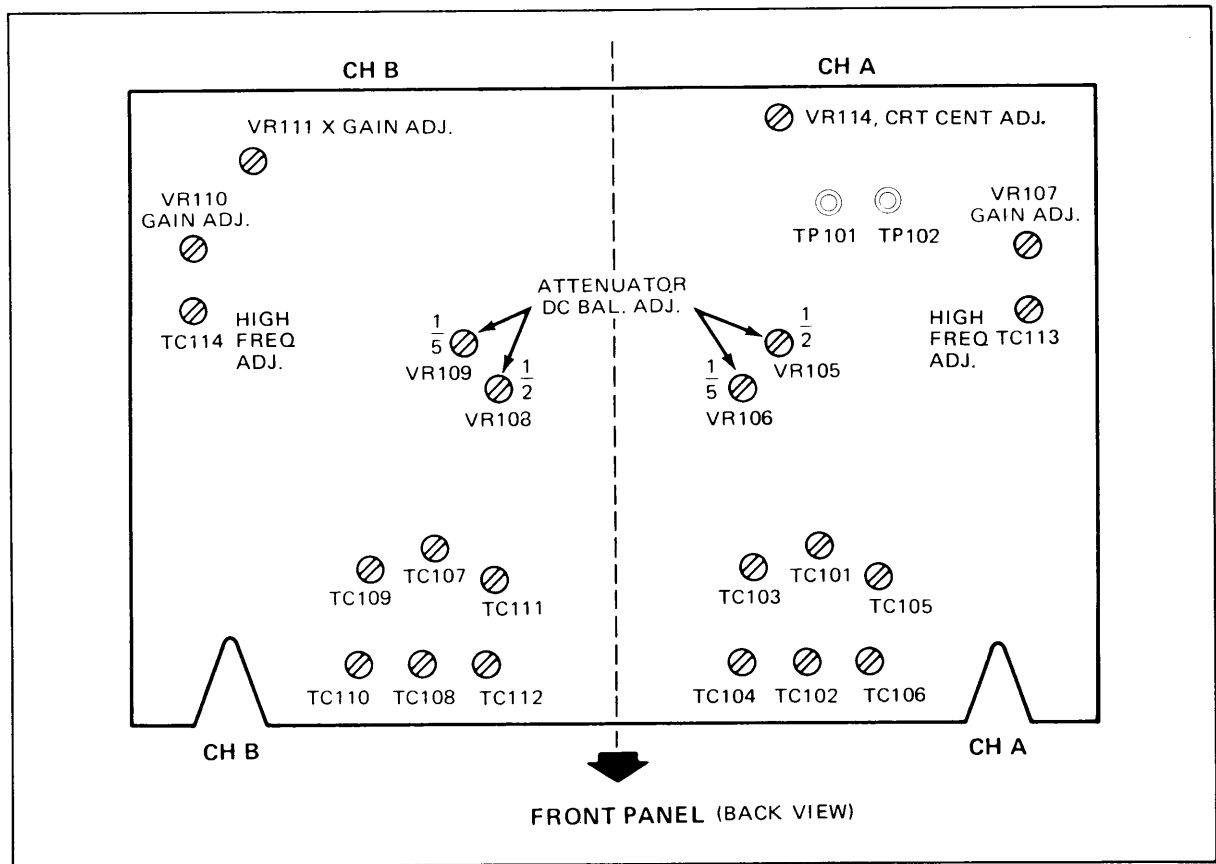

Fig. 56. Calibration diagram, vertical amplifier board.

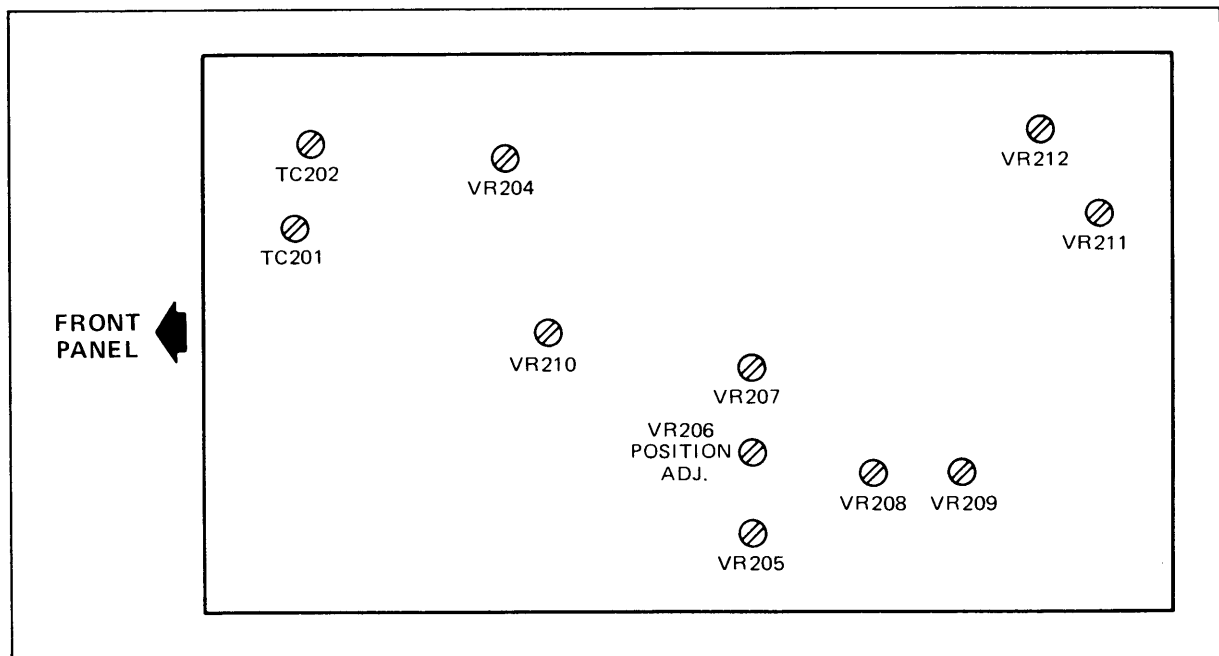

Fig. 57. Calibration diagram, horizontal amplifier board.

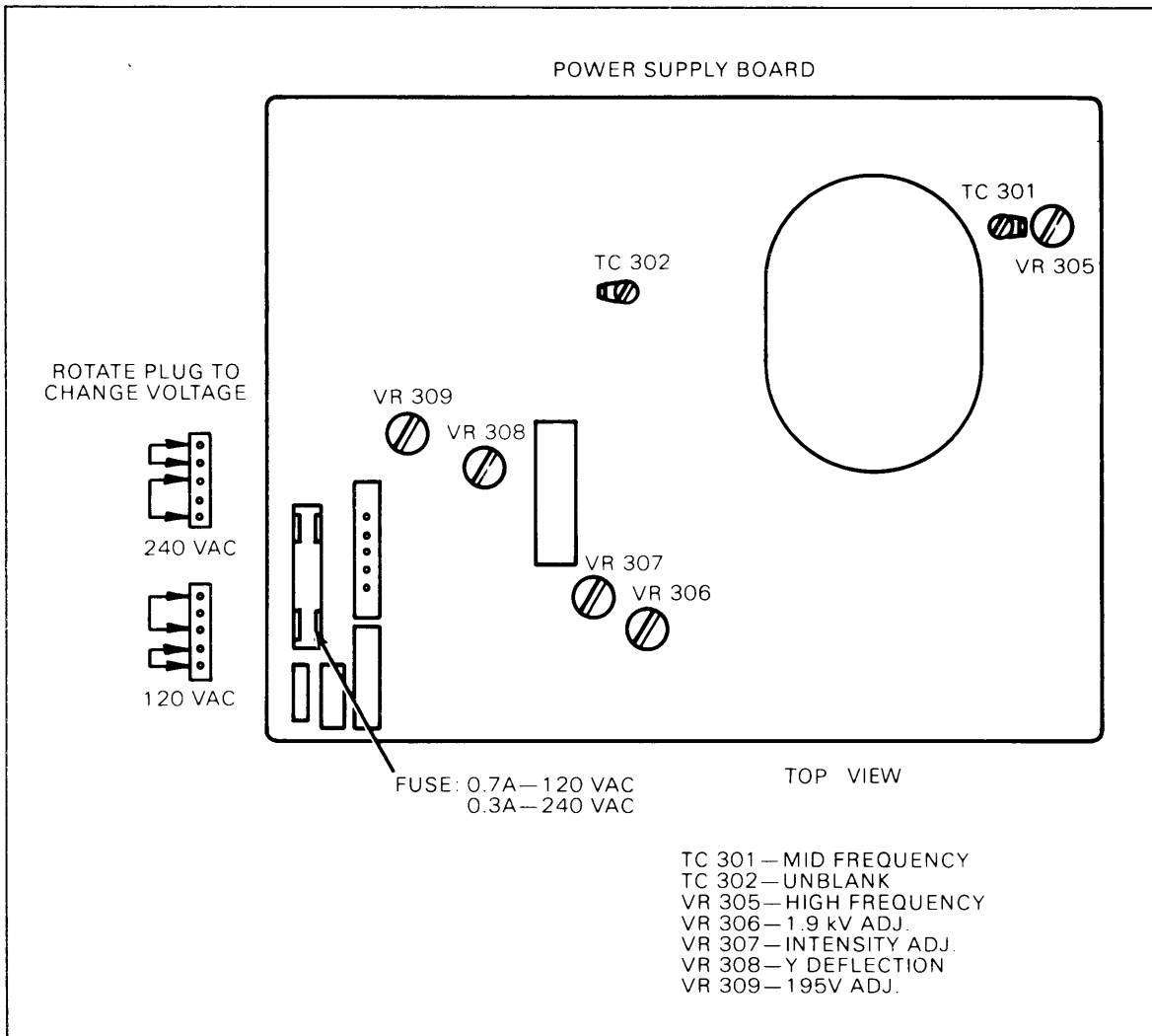

Fig. 58. Calibration diagram, power supply board.

WARRANTY SERVICE INSTRUCTIONS

1. Refer to the MAINTENANCE section of your B & K-Precision instruction manual for adjustments that may be applicable.
2. Defective parts removed from units which are within the One Year Limited Warranty period should be sent PREPAID to the Service Department listed below. Be sure to state the model and serial number of the unit from which the parts were removed and date the unit was purchased. These parts will be exchanged at no charge, under the terms of the Warranty.
3. If the above-mentioned procedures do not correct the problem you are experiencing with your unit, pack it securely (preferably in the original carton or double-packed). Enclose a letter describing the problem and include your name and address. Deliver to, or ship PREPAID (UPS preferred) to the nearest B & K-Precision authorized service agency (see list enclosed with unit).

If your list of authorized B & K-Precision service agencies has been misplaced, contact your local distributor for the name of your nearest service agency, or write to:

Service Department

B & K-Precision Product Group
DYNASCAN CORPORATION
2815 West Irving Park Road
Chicago, Illinois 60618



ONE YEAR LIMITED WARRANTY

DYNASCAN warrants that each product manufactured by it will be free from defects in material and workmanship under conditions of normal use and service for a period of one (1) year from the date of purchase from an authorized DYNASCAN distributor. DYNASCAN will, at its option, repair or replace any product or component not conforming with the foregoing warranty and which is returned, transportation prepaid, to our factory or our authorized service contractor. *DYNASCAN shall not otherwise be liable for any damages, consequential or otherwise.* DYNASCAN makes no other express warranties. *Any implied warranties (including any warranty of merchantability) are limited in duration to (1) one year from the date of purchase.* This warranty does not apply to (i) damage resulting from unauthorized alterations and repairs, misuse, negligency or accident; or (ii) damage resulting from improper installation, connection or adjustment otherwise than in accordance with DYNASCAN's authorized Instruction Manual. This warranty is void if the serial number has been altered, defaced or removed. DYNASCAN reserves the right to discontinue any model at any time or change specifications or design without notice and without incurring any obligation. To register this warranty, the enclosed DYNASCAN warranty registration card should be completed and mailed to DYNASCAN CORP., 6460 W. Cortland Street, Chicago, Illinois 60635, within ten (10) days after date of purchase.





DYNASCAN CORPORATION

6460 W. Cortland Street

Chicago, Illinois 60635